

### 1.4/1.6t Mast Specification

Type	Lifting height h <sub>1</sub>	Mast lowered h <sub>2</sub>	Mast extended h <sub>3</sub>	Free lifting height h <sub>4</sub>	Tilting range α/β
	mm	mm	mm	mm	(°)
Wide view duplex mast	2700	2000	3665	110	2/5
	3000	2150	3965	110	2/5
	3300	2300	4265	110	2/5
	3500	2400	4465	110	2/5
	3600	2450	4565	110	2/5
	4000	2700	4965	110	2/5
	4300	2840	5265	110	2/5
	4500	2950	5465	110	2/5
	4800	3145	5765	110	2/5
	5000	3245	5965	110	2/5
Full free triple mast	4000	2030	4965	1065	2/5
	4500	2160	5465	1195	2/5
	5000	2300	5965	1335	2/5
	5500	2450	6465	1485	2/5
	6000	2625	6965	1660	2/5
	6500	2800	7465	1835	2/5
	7000	3000	7965	2035	2/5
	7500	3060	8465	2095	2/5
	8000	3250	8965	2285	2/5
	8500	3420	9465	2455	2/5
	9000	3580	9965	2615	2/5
	9500	3760	10465	2795	2/5
	10000	3920	10965	2955	2/5
	10500	4100	11465	3135	2/5
	11000	4300	11965	3335	2/5

### 1.8t Mast Specification

Type	Lifting height h <sub>1</sub>	Mast lowered h <sub>2</sub>	Mast extended h <sub>3</sub>	Free lifting height h <sub>4</sub>	Tilting range α/β
	mm	mm	mm	mm	(°)
Wide view duplex mast	2700	2000	3665	110	2/5
	3000	2150	3965	110	2/5
	3300	2300	4265	110	2/5
	3500	2400	4465	110	2/5
	3600	2450	4565	110	2/5
	4000	2700	4965	110	2/5
	4300	2840	5265	110	2/5
	4500	2950	5465	110	2/5
	4800	3145	5765	110	2/5
	5000	3245	5965	110	2/5
Full free triple mast	4000	2165	5465	1200	2/5
	4500	2315	5965	1350	2/5
	5000	2490	6465	1525	2/5
	6000	2665	6965	1700	2/5
	6500	2835	7465	1870	2/5
	7000	3020	7965	2055	2/5
	7500	3180	8465	2215	2/5
	8000	3350	8965	2385	2/5
	8500	3500	9465	2515	2/5
	9000	3680	9965	2635	2/5
	9500	3870	10465	2805	2/5
	10000	4070	10965	2995	2/5
	10500	4280	11465	3205	2/5
	11000	4500	11965	3435	2/5

### 2.0t Mast Specification

Type	Lifting height h <sub>1</sub>	Mast lowered h <sub>2</sub>	Mast extended h <sub>3</sub>	Free lifting height h <sub>4</sub>	Tilting range α/β
	mm	mm	mm	mm	(°)
Wide view duplex mast	2700	2000	3665	110	2/5
	3000	2150	3965	110	2/5
	3300	2300	4265	110	2/5
	3500	2400	4465	110	2/5
	3600	2450	4565	110	2/5
	4000	2700	4965	110	2/5
	4300	2840	5265	110	2/5
	4500	2950	5465	110	2/5
	4800	3145	5765	110	2/5
	5000	3245	5965	110	2/5
Full free triple mast	4000	2085	4965	1120	2/5
	4500	2165	5465	1200	2/5
	5000	2315	5965	1350	2/5
	5500	2490	6465	1525	2/5
	6000	2665	6965	1700	2/5
	6500	2835	7465	1870	2/5
	7000	3020	7965	2055	2/5
	7500	3180	8465	2215	2/5
	8000	3350	8965	2385	2/5
	8500	3500	9465	2515	2/5
	9000	3680	9965	2635	2/5
	9500	3870	10465	2805	2/5
	10000	4070	10965	2995	2/5
	10500	4250	11465	3205	2/5
	11000	4450	11965	3435	2/5

\* When you choose the mast, the dimensions of the truck will be affected. Please refer to the performance parameter table for details.

### 2.5t Mast Specification

Type	Lifting height h <sub>1</sub>	Mast lowered h <sub>2</sub>	Mast extended h <sub>3</sub>	Free lifting height h <sub>4</sub>	Tilting range α/β
	mm	mm	mm	mm	(°)
Wide view duplex mast	2700	2000	3665	110	2/5
	3000	2150	3965	110	2/5
	3300	2300	4265	110	2/5
	3500	2400	4465	110	2/5
	3600	2450	4565	110	2/5
	4000	2700	4965	110	2/5
	4300	2840	5265	110	2/5
	4500	2950	5465	110	2/5
	4800	3145	5765	110	2/5
	5000	3245	5965	110	2/5
Full free triple mast	4000	2085	4965	1120	2/5
	4500	2165	5465	1200	2/5
	5000	2315	5965	1350	2/5
	5500	2490	6465	1525	2/5
	6000	2665	6965	1700	2/5
	6500	2835	7465	1870	2/5
	7000	3020	7965	2055	2/5
	7500	3180	8465	2215	2/5
	8000	3350	8965	2385	2/5
	8500	3500	9465	2515	2/5
	9000	3680	9965	2635	2/5
	9500	3870	10465	2805	2/5
	10000	4070	10965	2995	2/5
	10500	4250	11465	3205	2/5
	11000	4450	11965	3435	2/5

\* When you choose the mast, the dimensions of the truck will be affected. Please refer to the performance parameter table for details.



HANGCHA GROUP CO., LTD.

Factory site: 666 Xiangfu Road,  
Hangzhou, Zhejiang, China (311305)

Tel: +86-571-88926735 88926755  
Fax: +86-571-88926789 88132890

sales@hcforklift.com  
www.hcforklift.com



Follow us on  
Facebook



Follow us on  
YouTube



Follow us on  
WeChat



Download "Hangcha  
Forklift" App



ISO 14001  
ISO 14001:2015



ISO 9001  
ISO 9001:2015



HANGCHA trucks conform  
to the European Safety  
Requirements.

2025 VERSION 5/01/RIGHT 2025/08



# XC SERIES REACH TRUCK WITH LITHIUM POWER

with capacity of 1,400 to 2,500kg



The World of Hangcha  
SINCE 1956



HANGCHA GROUP CO., LTD. reserves the right to make any changes without notice concerning colors, equipment, or specifications detailed in this brochure, or to discontinue individual models. The colors of trucks, delivered may differ slightly from those in brochures.

# A NEW DIMENSION OF PERFORMANCE

## XC SERIES REACH TRUCK WITH LITHIUM POWER

- / The XC series reach truck with lithium power fully utilize the advantages of lithium battery and achieve disruptive innovations in vehicle structure, functional configuration, performance parameters, ergonomics, and operating vision.
- / We cater for a wide range of applications whilst ensuring optimum energy efficiency. Regardless of your special requirements – whether confined spaces or lifting height reaches 13m, load capacity of up to 2,500 kg or individual customisation with various options – we have the truck you need.
- / Compact size of the lithium battery pack and breaking through the traditional structure design, makes the truck style more novel and more efficient.

MAXIMUM TRAVELLING SPEED

**14km/h**

MAXIMUM LIFTING SPEED

**0.81m/s**

HIGH RESIDUAL CAPACITY

**6,500mm**

MAXIMUM LOAD CAPACITY

**2,500kg**

MAXIMUM LIFT HEIGHT

**13,000mm**



# BEING ENVIRONMENTALLY FRIENDLY, EFFICIENT AND DURABLE

- / CATL lithium battery is standard for all series, adopting 80V voltage system which can provides fast charging and long service life and less energy loss.
- / The special-shaped lithium battery pack design provides a large operating space in the cab and a broad view.



Charging port



Battery removal

 Working time > 10h

 Fast charging time ≤ 2h

Lithium battery capacity			Size	
CATL	1.4 t	Std.	80V/250Ah	S
	1.6 t			
	1.8 t			
	2.0 t	Opt.	80V/400Ah	L
	2.5 t			

Lithium battery capacity			Size	
EVE	1.4 t	Opt.	80V/304Ah	S
	1.6 t			
	1.8 t			
	2.0 t			
	2.5 t			



# A NOVEL PROFILE STYLE AND COMPACT INTERIOR DESIGN

With fewer exposed fasteners of the inside covers, the interior is compact and stylish.

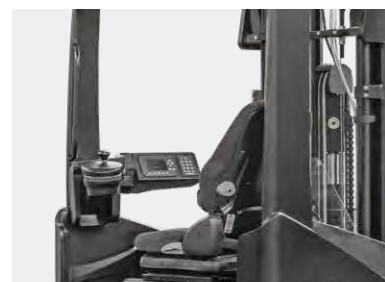
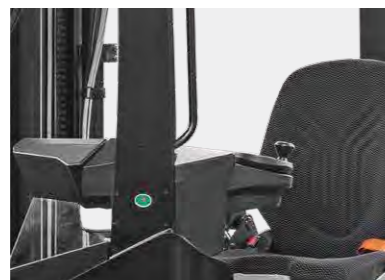

Thanks to the special-shaped design of the battery pack and the breakthrough in the body structure, which can provide a wider view.



## The improved mast structure and piping arrangement enables a broader vision for stacking operations

/ The hydraulic tubing and the wires are on both sides of the mast, overlapping with the chain, making full use of the space and reducing the line of sight.



The compact mast design enables operator have a wider view around the outside of the mast.

The middle cylinder is arranged eccentrically to enable the driver to have a wider view around the inside of the mast.

# EXCELLENT ERGONOMIC DESIGN

Dashboard angle adjustment

Control with a fingertip switch



Steering wheel position can also be adjusted



The pedal height can be adjusted electrically

Integral suspended seat



# MULTIFUNCTIONAL INTERACTIVE COLOR-SCREEN INSTRUMENTS

The new multifunctional 4.3 inch color-screen instruments developed for the XC series reach truck have easier human-machine interfaces.



## More status indication



1

1. Lifting height  
2. Local time  
3. Load weight

2

1. Driving mode  
2. Fork action  
3. Operating time  
4. Maximum allowable lifting height

3

1. Steering mode  
2. Battery power  
3. Travelling speed

4

Various status signs and warning signs are displayed in a queue according to actual needs

## More convenient shortcut button

Thanks to the integrated design of the instrument function buttons, the truck console saves a lot of physical buttons, making it more concise and efficient.



5

Height selection

6

Height limit

7

Lighting control

8

Battery removal

9

Optional function switching screen

10

↑ Button Driving mode switching

11

↓ Button Turtle speed mode

# COMPREHENSIVELY IMPROVED FUNCTION CONFIGURATION



## Height selection

Multiple heights can be pre-set on the instrument. After the function is enabled, when the fork is about to be lifted to the preset height, the lifting speed will gradually slow down and the fork will finally stop at the set height steadily.

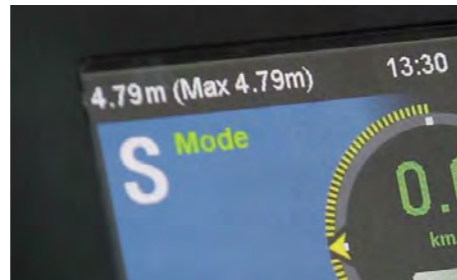

## Height limit

After this function is enabled, when the fork is lifted to a certain height, this height will be set as the maximum allowable lifting height. Afterwards, whenever the fork is about to be lifted to this height, the lifting speed will gradually slow down and the fork will steadily finally stop at this height.



## Central sideshift

Simple, reliable and fast: The central positioning of the sideshift occurs automatically, eliminating the time-consuming, cautious approach of the required position. (Only for fingertip system)

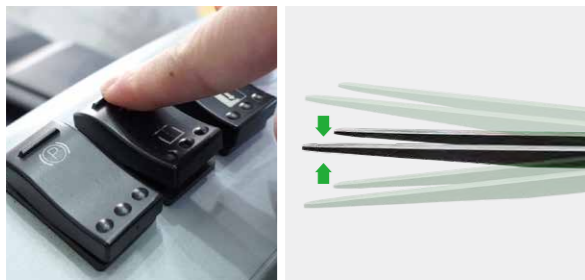

## Horizontal fork

Particularly at high lift heights, the forks' tilt position is often very hard to detect. The automatic horizontal positioning significantly simplifies and accelerates pallet entry. (Only for fingertip system)



**Faster, easier and safer stacking and retrieval operations**

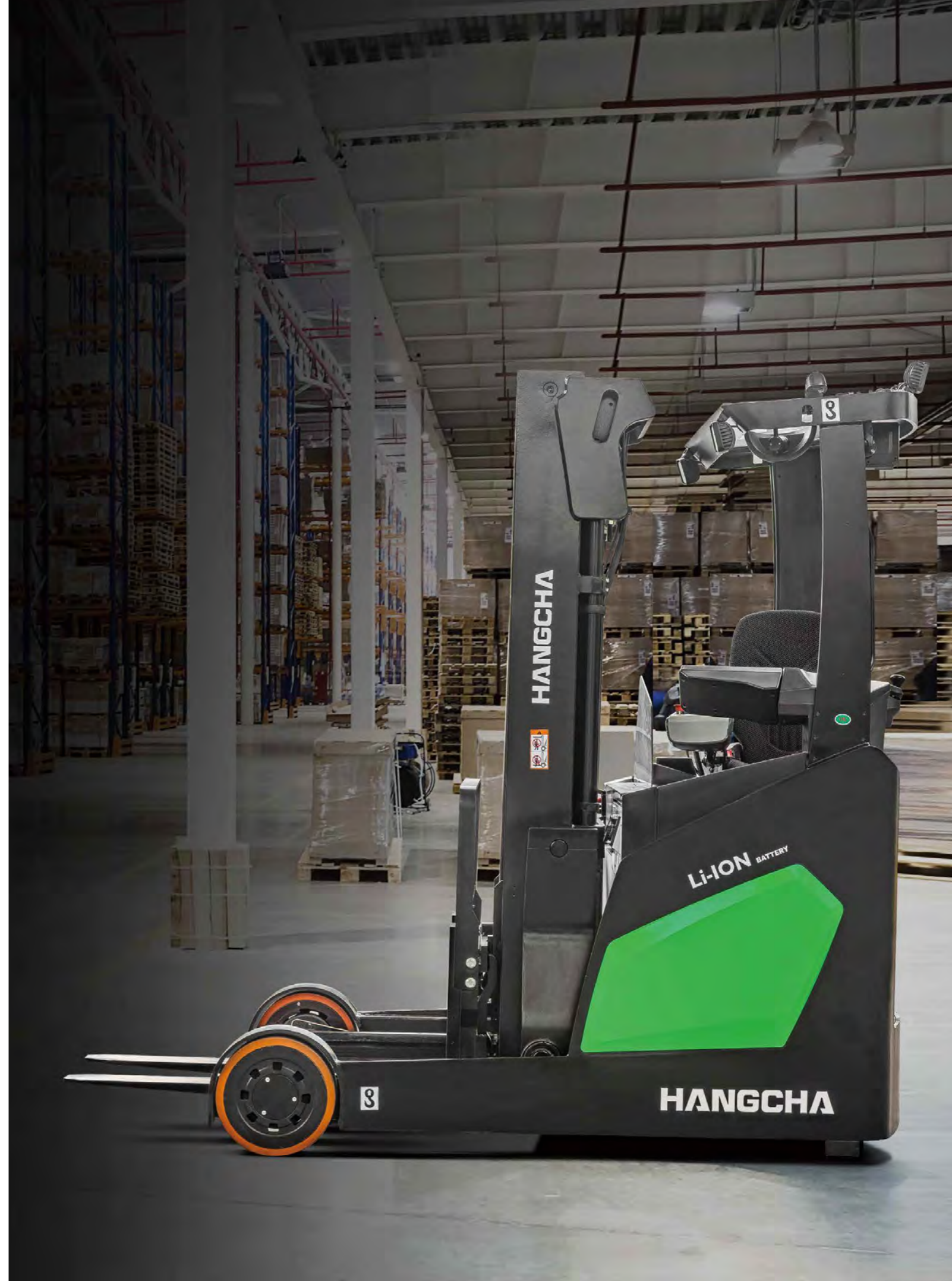



# SAFETY FROM EVERY ANGLE

## Drive control limit

Drive control limits the travelling speed and traverse speed as soon as the forks are raised. This increases the safety when manoeuvring with a raised pallet in front of the storage rack, while still ensuring more sensitive manoeuvring during the work cycle.

Traverse speeds (mm/s)

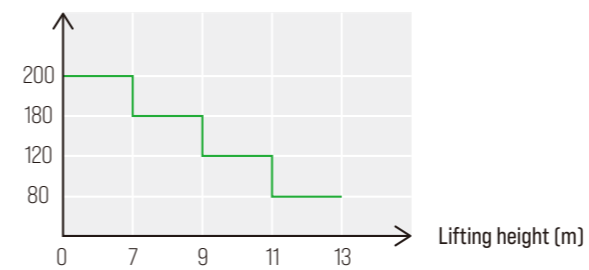

Travelling speed (km/h)

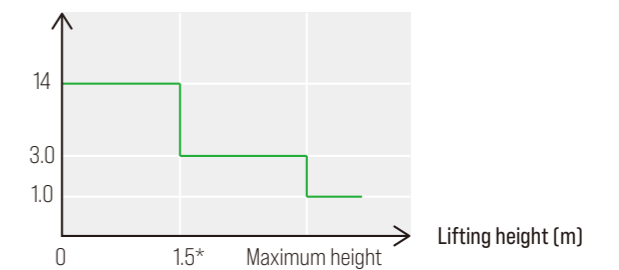

**Note:** The above table is only for 2.0/2.5t, the parameters of other models are not the same.

\*: 1.5m is only for the fingertip system. The parameter of mechanical control system is the height of free lift.



The battery is in an inappropriate position and the indicator light is lit

## Battery lock with creep speed interlock

Installed on the battery latch in the motor compartment. Monitors the locking of the battery pack. If the battery pack is not retracted or not locked, travel is restricted to creep speed.



# EASY MAINTENANCE

The battery pack can be replaced quickly. The driver can unlock and remove the battery while sitting on his seat.

Remove battery pack step



The hood can be easily dismantled and mounted to facilitate routine maintenance operations.

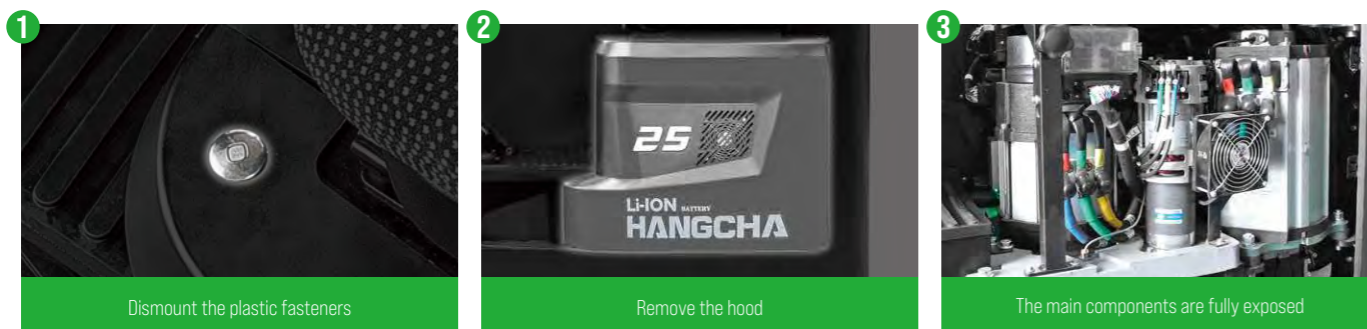

The seat can be turned open at a large angle, which is convenient for maintenance work.

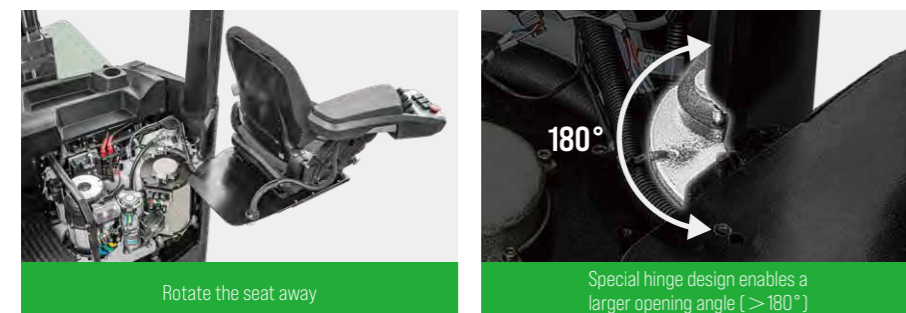



# WE GIVE YOU ALL THE OPTIONS



## Stacking and retrieval via video monitoring

Our video camera allows for the precise and quick access of extremely high locations. The position of the camera on the forks enables operators to efficiently and reliably control stacking and retrieval operations from their seating position/viewpoint. They no longer have to look up, which noticeably reduces the strain on their shoulders and neck. Also, information on the pallets is easily visible, even at great heights.



## Easier stacking and retrieval with positioning laser

Our positioning lasers significantly simplify the stacking and retrieval process and increase the safety for load and rack. The laser sources are integrated into the fork tips, projecting a red line on the area ahead. This allows the operator to adjust the fork more accurately to be able to drive effortlessly into the pallet.



## Easy access

Easy access protects the reach truck against unauthorised use. Authorisation management is directly controlled via the truck's display. Customised to your requirements and company size – you can choose between the key (Std.), PIN code and transponder.



## Safety at any blind spots with Floor Spot

Floor Spot projects a blue dot on the floor around the truck. Especially at blind intersections or at the end of rack aisles, the Floor Spot alerts an approaching truck in time to respond.

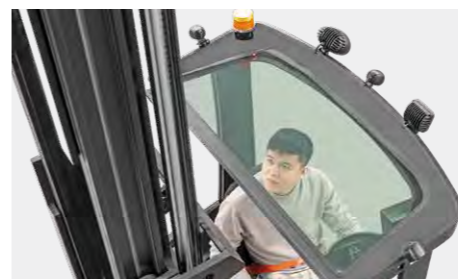

## 100% clear view thanks to panorama roof panel

Maximum visibility: The panorama roof panel without cross beams provides maximum visibility of the goods and forks.



## Optimum traction via traction control system

Optimum traction is ensured with braking of the drive wheel, which would otherwise spin on wet or dusty floors.

# XC Series Reach Truck With Cab Is A **COLD STORAGE PRODUCT**

(meeting the  $-30^{\circ}\text{C}$  cold storage environment).



/ The front, rear, top, and side windows are all made of large area tempered glass, and are equipped with front, rear, and top window wipers as standard to enhance the driver's visibility.

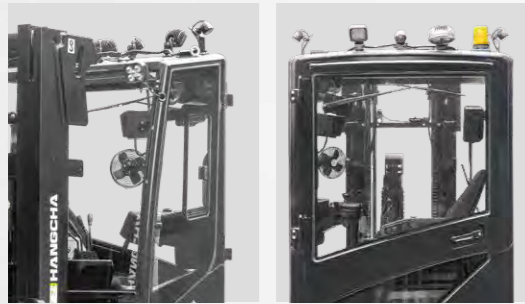

/ High power fan heater is optional to further increase the temperature in the cab (test data: the temperature in the cab can be increased to  $10^{\circ}\text{C}$  by operating in the  $-30^{\circ}\text{C}$  cold storage).



Equipped with a fully enclosed cab, it has excellent performance in rust prevention, short circuit prevention, waterproofing, and insulation, meeting the usage environment of  $-30^{\circ}\text{C}$  (test data: operating in a  $-30^{\circ}\text{C}$  cold storage, the cab temperature is higher than  $0^{\circ}\text{C}$  )





## Features

NO.	System	Features	CQD14/16/18/20/25-XC5-SI*	CQD14/16/18/20/25-XC5D-SI*	CQD14/16/18/20/25-XC5-SIJS*	CQD14/16/18/20/25-XC5D-SIJS*	
1	Applicable environment	Cold storage model (-30 °C)	○	○	●	●	
2		Full closed cab	/	/	●	●	
3	Control	Control with a mechanical control lever	●	/	●	/	
4		Control with a fingertip switch	/	●	/	●	
5		Height display	○ (Only for triplex mast, excluding the free lift range)	● (Including the free lift range)	○ (Only for triplex mast, excluding the free lift range)	● (Including the free lift range)	
6		Height selection	○ (Only for triplex mast, excluding the free lift range)	● (Including the free lift range)	○ (Only for triplex mast, excluding the free lift range)	● (Including the free lift range)	
7		Height limit	○ (Only for triplex mast, excluding the free lift range)	● (Including the free lift range)	○ (Only for triplex mast, excluding the free lift range)	● (Including the free lift range)	
8		Central sideshift	/	○	/	○	
9		Horizontal fork alignment	/	○	/	○	
10		Mast reach damping system	●	●	●	●	
11		Electric lowering limit - Stop forks above outriggers if mast is retracted	○	○	○	○	
12		Soft landing system	/	○	/	○	
13		Lifting damping system	●	●	●	●	
14		Drive control limit	●	●	●	●	
15		Drive wheel skid control system	○	○	○	○	
16		Battery lock with creep speed interlock	●	●	●	●	
17		Travelling speed control at corner	●	●	●	●	
18		180° steering mode	●	●	●	●	
19		360° steering mode	○	○	○	○	
20		Transmission system	ZF transmission	●	●	●	●
21		Electronic accessories	USB power socket	●	●	●	●
22	Fork video monitoring and positioning laser		○	○	○	○	
23	Keyed start		●	●	●	●	
24	Start with a PIN code or by a card		○	○	○	○	
25	Beep		○	○	○	○	
26	Operating light (in the direction of the fork)		●	●	●	●	
27	Operating light (in the reverse direction of the fork)		○	○	○	○	
28	Alarm light		●	●	●	●	
29	Blue light		○	○	○	○	
30	Three-sided one line laser projection light		○	○	○	○	
31	Reading light in the car		/	/	●	●	
32	Double-speed wind speed heater		/	/	●	●	
33	Electric fan		○	○	○	○	
34	The front window glass double-speed wiper		/	/	●	●	
35	Back window glass double-speed wiper		/	/	●	●	
36	Top window glass double-speed wiper		/	/	●	●	
37	Front window glass spray water		/	/	●	●	
38	Ergonomic design	Electrical adjustment of pedal height	○	○	○	○	
39		Adjustable steering wheel	●	●	●	●	
40	Instrument angle adjustment	●	●	●	●		
41	Fault Diagnosis	Suctioned oil filter clogging alarm	○	○	○	○	
42		Backflow oil filter clogging alarm	○	●	○	●	
43	Seat	Sequential Seat Belt Interlock System	●	●	●	●	
44		BF6-3 suspension seat	●	/	●	/	
45	MS665/522 suspension seat	○	●	/	●		
46	Other	Panorama roof	○	○	●	●	
47		PVC ceiling	○	○	/	/	
48		The side glass can be opened	/	/	●	●	
49		Broken window	/	/	●	●	
50		Battery side roll out (Excluding the 2.0t truck with mast lift height ≧ 12m)	○	○	○	○	
51		Battery side roll out (Excluding 1.4t truck with size L battery)	○	○	○	○	
52		Curved rearview mirror	○	○	○	○	
53		Left and right rear view mirrors	○	○	/	/	
54		Load backrest	●	●	●	●	
55		Fire extinguisher	○	○	○	○	
56		OPS system	●	●	●	●	
57		Simultaneous lift and reach (The lift speed will be reduced by 10%, and reach speed will be reduced by 30%).	/	○	/	○	

Note: ● Standard; ○ Optional; / Not available  
★ CE model

# XC Series Reach Truck With Lithium Power Specification

Distinguishing mark	1.1		HANGCHA GROUP CO.,LTD.						
	1.2	Manufacturer's type designation		CQD14-XC5-SI* CQD14-XC5D-SI*	CQD16-XC5-SI* CQD16-XC5D-SI*	CQD18-XC5-SI* CQD18-XC5D-SI*	CQD20-XC5-SI* CQD20-XC5D-SI*	CQD25-XC5-SI* CQD25-XC5D-SI*	
1.3	Drive: electric		Electric	Electric	Electric	Electric	Electric		
1.4	Operator type		Seated	Seated	Seated	Seated	Seated		
1.5	Rated capacity/rated load	Q (kg)	1400	1600	1800	2000	2500		
1.6	Load centre distance	c (mm)	600	600	600	600	600		
1.8	Load distance, centre of drive axle to fork	x (mm)	360 <sup>1)</sup>	410 <sup>1)</sup>	385	362 <sup>2)</sup>	484 <sup>2)</sup>		
1.9	Wheelbase	y (mm)	1355	1405	1405	1471	1601		
Weight	2.1	Service weight (incl.battery)	kg	3330	3370	3370	3470	3620	
		Service weight (without battery)	kg	3055	3095	3095	3195	3345	
Tyres, chassis	3.1	Tyres: solid rubber, superelastic, pneumatic, polyurethane		Polyurethane	Polyurethane	Polyurethane	Polyurethane	Polyurethane	
	3.2	Tyre size, front		Ø343×140	Ø343×140	Ø343×140	Ø343×140	Ø400×160	
	3.3	Tyre size, rear		Ø285×100	Ø285×100	Ø285×100	Ø343×108	Ø343×108	
	3.5	Wheels, number front / rear (x = driven wheels)		1×/2	1×/2	1×/2	1×/2	1×/2	
	3.7	Tread, rear	b11(mm)	1170	1170	1170	1162	1162	
Dimensions	4.1	Tilt of fork carriage forward/backward	α/β(°)	2/5	2/5	2/5	2/5	2/5	
	4.2	Height, mast lowered	h1 (mm)	2100	2100	2100	2100	2100	
	4.3	Free lift	h2 (mm)	105	105	110	110	110	
	4.4	Lift	h3 (mm)	3000	3000	3000	3000	3000	
	4.5	Height, mast extended	h4 (mm)	3965	3965	3965	3965	3965	
	4.7	Height of overhead guard	h6 (mm)	2264	2264	2264	2264	2264	
	4.8	Seat height relating to SIP	h7 (mm)	1159	1159	1159	1159	1159	
	4.19	Overall length	l1 (mm)	2400 <sup>2)</sup>	2400 <sup>3)</sup>	2425	2514 <sup>2)</sup>	2542 <sup>2)</sup>	
	4.20	Length to face of forks	l2 (mm)	1250 <sup>3)</sup>	1250 <sup>3)</sup>	1275	1364 <sup>2)</sup>	1392 <sup>2)</sup>	
	4.21	Overall width	b1/b2(mm)	1270/1270	1270/1270	1270/1270	1270/1270	1270/1270	
	4.22	Fork dimensions DIN ISO 2331	s/e/l (mm)	40×122×1150 <sup>2)</sup>	40×122×1150 <sup>2)</sup>	40×122×1150	40×122×1150	40×122×1150	
	4.23	Fork carriage ISO 2328, class/type A,B		2A	2A	2A	2A	2A	
	4.24	Fork-carriage width	b3 (mm)	830	830	830	830	830	
	4.25	Distance between fork-arms	b5 (mm)	750	750	750	750	750	
	4.26	Distance between wheel-arms	b4 (mm)	940	940	940	940	940	
	4.28	Reach distance	l4 (mm)	571 <sup>4)</sup>	621 <sup>4)</sup>	588	594 <sup>2)</sup>	716 <sup>2)</sup>	
	4.32	Ground clearance, centre of wheelbase	m2 (mm)	80	80	80	80	80	
	4.34.1	Aisle width for pallets 1000 x 1200 crossways	Ast (mm)	2687 <sup>2)</sup>	2701 <sup>3)</sup>	2719	2802 <sup>2)</sup>	2867 <sup>2)</sup>	
	4.34.2	Aisle width for pallets 800 x 1200 lengthways	Ast (mm)	2740 <sup>3)</sup>	2745 <sup>3)</sup>	2768	2855 <sup>2)</sup>	2896 <sup>2)</sup>	
	4.35	Turning radius	Wa (mm)	1610	1660	1660	1726	1876	
	4.37	Length across wheel arms	l7 (mm)	1775	1825	1825	1920	2070	
	Performance data	5.1	Travel speed, laden/unladen	km/h	14/14	14/14	14/14	14/14	14/14
		5.2	Lift speed, laden/unladen	m/s	0.61/0.81	0.59/0.81	0.5/0.7	0.48/0.7	0.45/0.7
5.3		Lowering speed, laden/unladen	m/s	XC5:0.52/0.52	XC5:0.52/0.52	XC5:0.52/0.52	XC5:0.52/0.52	XC5:0.52/0.52	
				XC5D:0.56/0.56	XC5D:0.56/0.56	XC5D:0.56/0.56	XC5D:0.56/0.56	XC5D:0.56/0.56	
5.4		Reaching speed, laden/unladen	mm/s	240/240	240/240	200/200	200/200	200/200	
5.8		Max. gradeability, laden/unladen	%	10/15	10/15	10/15	10/15	10/15	
5.10	Service brake		Electric+Mech.	Electric+Mech.	Electric+Mech.	Electric+Mech.	Electric+Mech.		
	Parking brake		Electric	Electric	Electric	Electric	Electric		
Electric-engine	6.1	Drive motor rating S2 60 min	kW	8.1 AC	8.1 AC	8.1 AC	8.1 AC	8.1 AC	
	6.2	Lift motor rating at S3 15%	kW	20 AC	20 AC	20 AC	20 AC	20 AC	
	6.3	Battery acc. to DIN 43531/35/36 A,B,C, no		no	no	no	no	no	
		Battery voltage, nominal capacity	V/Ah	80 /250	80 /250	80 /250	80 /250	80 /250	
	Battery weight	kg	275	275	275	275	275		

Note: 1) h3>7000mm:-25mm. 2) h3>7000mm:-8mm. 3) h3>7000mm:+25mm. 4) h3>7000mm:-33mm. 5) h3>7000mm:+19mm. 6) h3>7000mm:+23mm. 20) h3=12000mm:-150mm. 21) h3=12000mm:+150mm.

22) h3=12000mm:+115mm. 23) h3=12000mm:+137mm. 24) h3=12000mm:+105mm. 25) h3=12000mm:+134mm. 26) With optional Full free triple mast:35×100×1150.

★ CE model

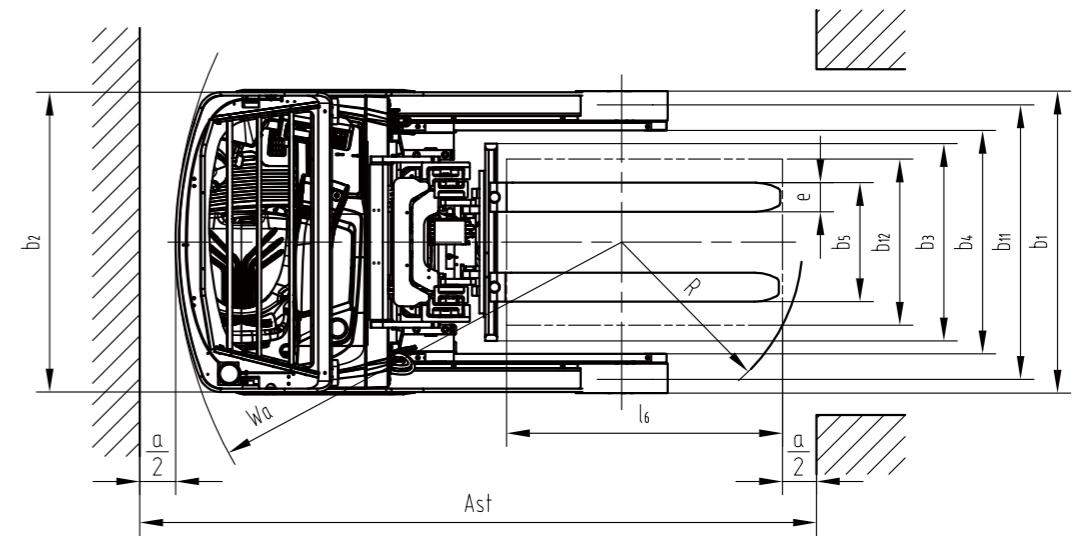
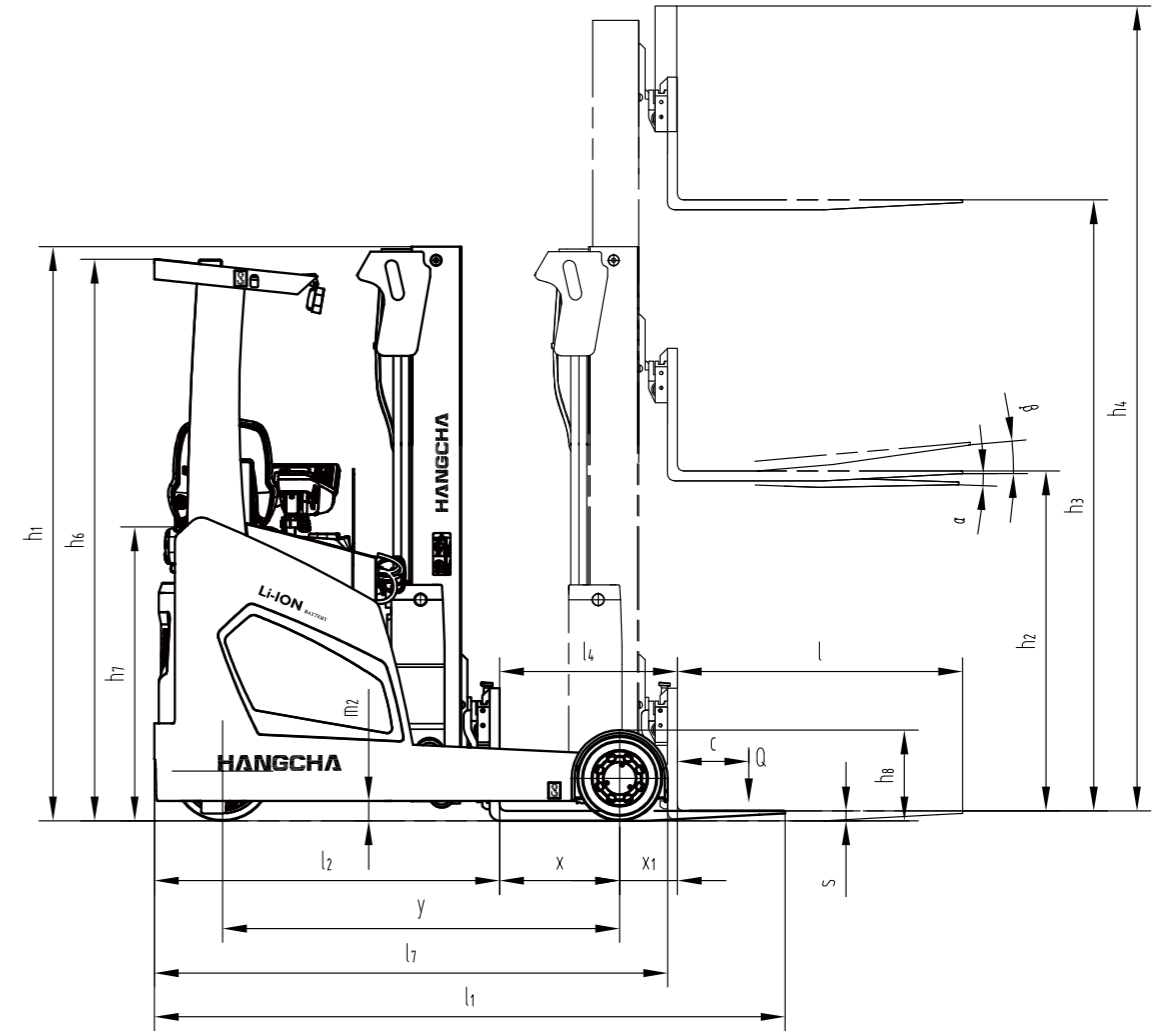

$$A_{st} = W_a + R + a = W_a + \sqrt{(l_6 - x)^2 + \left(\frac{b_{12}}{2}\right)^2} + a$$

# XC Series Reach Truck With Cab Specification

Distinguishing mark	HANGCHA GROUP CO.,LTD.							
	1.1	Manufacturer	CQD14-XC50-SUS* CQD14-XC5-SUS*	CQD16-XC50-SUS* CQD16-XC5-SUS*	CQD18-XC50-SUS* CQD18-XC5-SUS*	CQD20-XC50-SUS* CQD20-XC5-SUS*	CQD25-XC50-SUS* CQD25-XC5-SUS*	
1.2	Manufacturer's type designation							
1.3	Drive: electric		Electric	Electric	Electric	Electric	Electric	
1.4	Operator type		Seated	Seated	Seated	Seated	Seated	
1.5	Rated capacity/rated load	Q (kg)	1400	1600	1800	2000	2500	
1.6	Load centre distance	c (mm)	600	600	600	600	600	
1.8	Load distance, centre of drive axle to fork	x (mm)	282 <sup>2)</sup>	332 <sup>2)</sup>	307	362 <sup>2)</sup>	484 <sup>2)</sup>	
1.9	Wheelbase	y (mm)	1355	1405	1405	1471	1601	
2.1	Service weight(incl.battery)	kg	3460	3500	3500	3600	3681	
	Service weight(without battery)	kg	3185	3225	3225	3325	3406	
Tyres, chassis	3.1	Tyres: solid rubber, superelastic, pneumatic, polyurethane	Polyurethane	Polyurethane	Polyurethane	Polyurethane	Polyurethane	
	3.2	Tyre size, front	Ø343×140	Ø343×140	Ø343×140	Ø343×140	Ø400×160	
	3.3	Tyre size, rear	Ø285×100	Ø285×100	Ø285×100	Ø343×108	Ø343×108	
	3.5	Wheels, number front / rear (x = driven wheels)	1×/2	1×/2	1×/2	1×/2	1×/2	
	3.7	Tread, rear	b11(mm)	1170	1170	1170	1182	
Dimensions	4.1	Tilt of fork carriage forward/backward	α/β(°)	2/5	2/5	2/5	2/5	2/5
	4.2	Height, mast lowered	h1 (mm)	2100	2100	2100	2100	2100
	4.3	Free lift	h2 (mm)	105	105	110	110	110
	4.4	Lift	h3 (mm)	3000	3000	3000	3000	3000
	4.5	Height, mast extended	h4 (mm)	3965	3965	3965	3965	3965
	4.7	Height of overhead guard	h6 (mm)	2264	2264	2264	2264	2264
	4.8	Seat height relating to SIP	h7 (mm)	1159	1159	1159	1159	1159
	4.9	Overall length	l1 (mm)	2558 <sup>4)</sup>	2558 <sup>4)</sup>	2425	2594 <sup>4)</sup>	2622 <sup>4)</sup>
	4.20	Length to face of forks	l2 (mm)	1408 <sup>4)</sup>	1408 <sup>4)</sup>	1433	1444 <sup>2)</sup>	1472 <sup>2)</sup>
	4.21	Overall width	b1/b2(mm)	1270/1270	1270/1270	1270/1270	1270/1270	1270/1270
	4.22	Fork dimensions DIN ISO 2331	s/e/l (mm)	40×122×1150 <sup>2)</sup>	40×122×1150 <sup>2)</sup>	40×122×1150	40×122×1150	40×122×1150
	4.23	Fork carriage ISO 2328, class/type A/B		2A	2A	2A	2A	2A
	4.24	Fork-carriage width	b3 (mm)	830	830	830	830	830
	4.25	Distance between fork-arms	b5 (mm)	750	750	750	750	750
	4.26	Distance between wheel-arms	b4 (mm)	940	940	940	940	940
	4.28	Reach distance	l4 (mm)	493 <sup>4)</sup>	543 <sup>4)</sup>	510	594 <sup>2)</sup>	716 <sup>2)</sup>
	4.32	Ground clearance, centre of wheelbase	m2 (mm)	80	80	80	80	80
	4.34.1	Aisle width for pallets 1000 x 1200 crossways	Ast (mm)	2826 <sup>4)</sup>	2838 <sup>4)</sup>	2857	2882 <sup>2)</sup>	2947 <sup>2)</sup>
	4.34.2	Aisle width for pallets 800 x 1200 lengthways	Ast (mm)	2881 <sup>4)</sup>	2896 <sup>4)</sup>	2918	2935 <sup>2)</sup>	2976 <sup>2)</sup>
	4.35	Turning radius	Wa (mm)	1690	1740	1740	1806	1956
4.37	Length across wheel arms	l7 (mm)	1855	1905	1905	2000	2150	
Performance data	5.1	Travel speed,laden/unladen	km/h	14/14	14/14	14/14	14/14	14/14
	5.2	Lift speed, laden/unladen	m/s	0.61/0.81	0.59/0.81	0.5/0.7	0.48/0.7	0.45/0.7
	5.3	Lowering speed, laden/unladen	m/s	XC5:0.52/0.52 XC50:0.56/0.56	XC5:0.52/0.52 XC50:0.56/0.56	XC5:0.52/0.52 XC50:0.56/0.56	XC5:0.52/0.52 XC50:0.56/0.56	XC5:0.52/0.52 XC50:0.56/0.56
	5.4	Reaching speed, laden/unladen	mm/s	240/240	240/240	200/200	200/200	200/200
	5.8	Max. gradeability, laden/unladen	%	10/15	10/15	10/15	10/15	10/15
5.10	Service brake		Electric+Mech.	Electric+Mech.	Electric+Mech.	Electric+Mech.	Electric+Mech.	
	Parking brake		Electric	Electric	Electric	Electric	Electric	
Electric-engine	6.1	Drive motor rating S2 60 min	kW	8.1 AC	8.1 AC	8.1 AC	8.1 AC	8.1 AC
	6.2	Lift motor rating at S3 15%	kW	20 AC	20 AC	20 AC	20 AC	20 AC
	6.3	Battery acc. to DIN 43531/35/36 A,B,C, no		no	no	no	no	no
		Battery voltage, nominal capacity	V/Ah	80 /250	80 /250	80 /250	80 /250	80 /250
	Battery weight	kg	275	275	275	275	275	

Note: 1) h3>7000mm:-25mm, 2) h3>7000mm:-8mm, 3) h3>7000mm:+25mm, 4) h3>7000mm:-33mm, 5) h3>7000mm:+19mm, 6) h3>7000mm:+23mm, 20) h3>12000mm:-150mm.  
 21) h3>12000mm:+150mm, 22) h3>12000mm:+115mm, 23) h3>12000mm:+137mm, 24) h3>12000mm:+105mm, 25) h3>12000mm:+134mm; 26) With optional Full free triple mast:35×100×1150.  
 ★ CE model

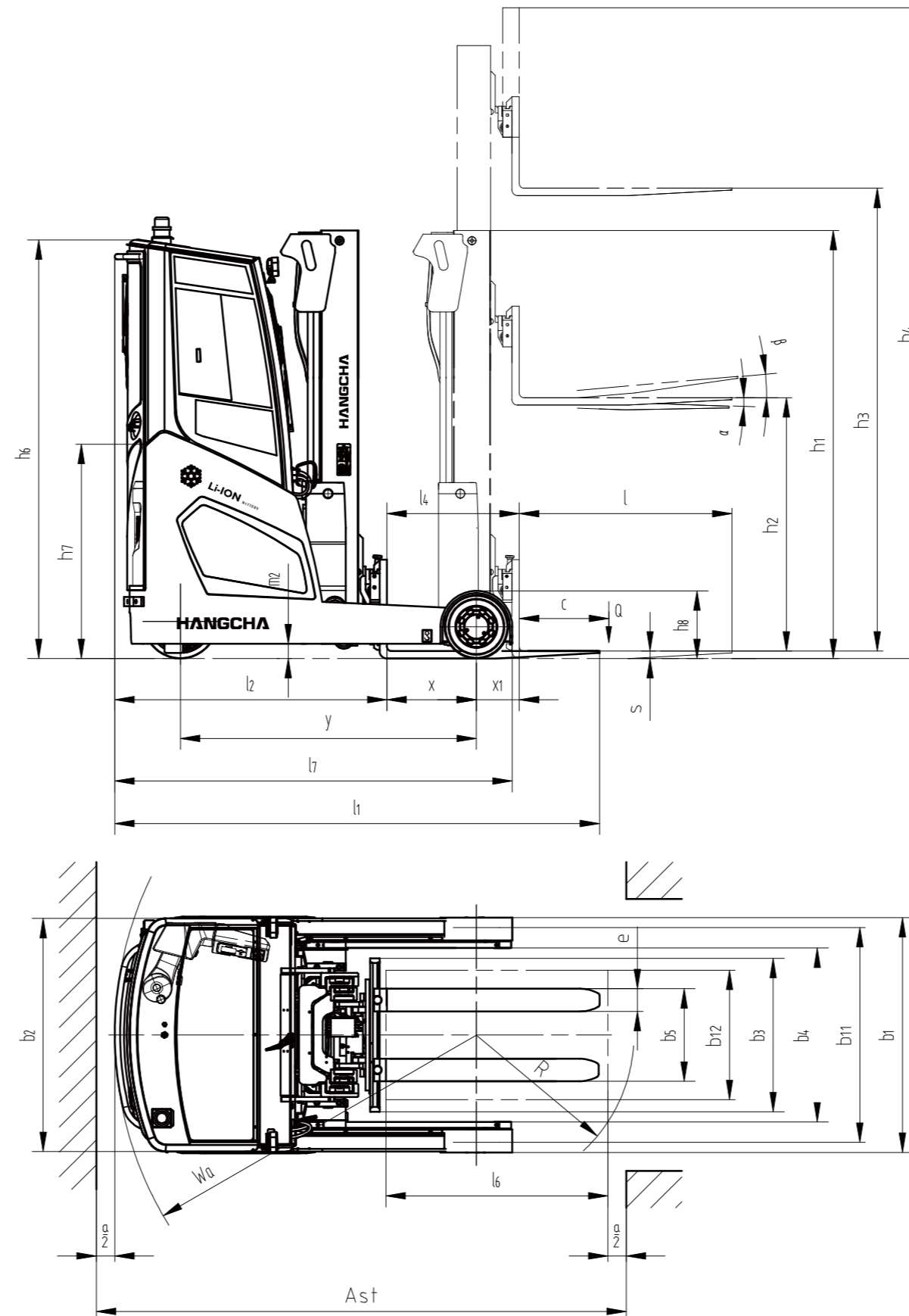

$$Ast = Wa + R + a = Wa + \sqrt{(l_6 - x)^2 + \left(\frac{b_{12}}{2}\right)^2} + a$$

## 1.4t Residual Load Capacity Chart

Capacity(kg)	Load center distance(mm)							
	600	700	800	900	1000	1100	1200	
≤6000	1400	1210	1070	920	780	660	550	
6500	1300	1120	990	840	720	600	490	
7000	1200	1030	910	770	650	540	430	
7500	1100	940	830	700	580	470	370	
8000	1050	900	790	660	550	440	350	
8500	1000	850	750	620	510	410	320	
9000	900	770	670	550	450	350	260	
9500	800	680	590	480	380	290	200	
10000	700	590	510	400	310	230	150	
10500	550	450	390	300	210	130	60	
11000	350	280	230	150	80	10	0	

## 1.6t Residual Load Capacity Chart

Capacity(kg)	Load center distance(mm)							
	600	700	800	900	1000	1100	1200	
≤6000	1600	1390	1230	1060	920	780	660	
6500	1500	1300	1150	990	850	720	610	
7000	1400	1210	1070	920	780	660	550	
7500	1300	1120	990	840	710	600	490	
8000	1250	1080	950	810	680	570	460	
8500	1200	1030	910	770	650	530	430	
9000	1100	940	830	700	580	470	370	
9500	1000	850	750	620	510	410	320	
10000	900	770	670	550	450	350	260	
10500	750	630	550	440	350	260	170	
11000	550	450	390	300	210	130	60	

## 1.8t Residual Load Capacity Chart

Capacity(kg)	Load center distance(mm)							
	600	700	800	900	1000	1100	1200	
≤6000	1800	1570	1390	1210	1050	900	780	
6500	1700	1480	1310	1130	980	840	720	
7000	1600	1390	1230	1060	910	780	660	
7500	1500	1300	1150	990	850	720	600	
8000	1450	1250	1110	950	810	680	570	
8500	1400	1210	1070	910	780	660	550	
9000	1300	1120	990	840	710	600	490	
9500	1200	1030	910	770	650	530	430	
10000	1100	940	830	700	580	470	370	
10500	950	810	710	590	480	380	290	
11000	750	630	550	440	350	260	170	
11500	550	450	390	300	210	130	60	

## 2.0t Residual Load Capacity Chart

Capacity(kg)	Load center distance(mm)							
	600	700	800	900	1000	1100	1200	
≤6500	2000	1750	1560	1360	1200	1040	910	
7000	1950	1710	1520	1330	1160	1010	880	
7500	1850	1620	1440	1250	1090	950	820	
8000	1800	1570	1400	1220	1060	920	790	
8500	1750	1530	1360	1180	1030	890	760	
9000	1650	1440	1280	1110	960	830	700	
9500	1550	1350	1190	1030	890	760	650	
10000	1450	1260	1110	960	820	700	590	
10500	1300	1130	990	850	720	610	500	
11000	1000	860	750	630	520	420	330	
11500	800	680	590	480	390	290	210	
12000	750	630	550	450	350	260	180	
12500	650	550	470	370	280	200	120	
13000	500	410	350	260	180	110	40	

## 2.5t Residual Load Capacity Chart

Capacity(kg)	Load center distance(mm)							
	600	700	800	900	1000	1100	1200	
≤6500	2500	2200	1960	1730	1530	1360	1200	
7000	2450	2150	1920	1700	1500	1330	1170	
7500	2350	2060	1840	1620	1430	1260	1110	
8000	2300	2020	1800	1590	1400	1230	1080	
8500	2250	1970	1760	1550	1360	1200	1050	
9000	2150	1880	1680	1480	1300	1140	990	
9500	2050	1800	1600	1400	1230	1080	940	
10000	1950	1710	1520	1330	1160	1010	880	
10500	1800	1570	1400	1220	1060	920	790	
11000	1500	1300	1150	1000	860	730	620	
11500	1300	1130	990	850	720	610	500	
12000	1250	1080	950	810	690	580	470	
12500	1150	990	870	740	620	510	410	
13000	1000	860	750	630	520	420	330	

## 2.0t Residual Load Capacity Chart(Truck With Cab)

Capacity(kg)	Load center distance(mm)							
	600	700	800	900	1000	1100	1200	
≤6500	2000	1750	1560	1360	1200	1040	910	
7000	1950	1710	1520	1330	1160	1010	880	
7500	1850	1620	1440	1250	1090	950	820	
8000	1800	1570	1400	1220	1060	920	790	
8500	1750	1530	1360	1180	1030	890	760	
9000	1650	1440	1280	1110	960	830	700	
9500	1550	1350	1190	1030	890	760	650	
10000	1450							