



**HANGCHA GROUP CO., LTD.**

**Factory site:** 666 Xiangfu Road,  
Hangzhou, Zhejiang, China (311305)

Tel: +86-571-88926735 88926755  
Fax: +86-571-88926789 88132890

sales@hcforklift.com  
www.hcforklift.com



Follow us on  
Facebook



Follow us on  
YouTube



Follow us on  
WeChat



Download "Hangcha  
Forklift" App



ISO45001  
ISO45001:2018



ISO14001  
ISO14001:2015



ISO9001  
ISO9001:2015



HANGCHA trucks conform  
to the European Safety  
Requirements.

2025 VERSION 4/COPYRIGHT 2025/09

HANGCHA GROUP CO., LTD. reserves the right to make any changes without notice concerning colors, equipment, or specifications detailed in this brochure, or to discontinue individual models. The colors of trucks, delivered may differ slightly from those in brochures.



## AE Series Electric Forklift

with capacities of 1,500 to 3,500kg

*The World of Hangcha*  
SINCE 1956



# AE Series Electric Forklift

Independently developed by Hangcha on the basis of more than 30 years of electric forklift research and development and accumulated manufacturing technology, the AE series electric forklifts are a new series of high-efficiency and energy-saving electric counterweight forklifts with a new structure that represents a breakthrough over the traditional design concept. The research and development of control and power systems are innovated and the product exterior, ergonomics, reliability, maintenance and other aspects are optimized, so that the performance of the vehicle is greatly improved.

## Appearance

- / With a profile formed by a combination of straight lines and streamlined curved surfaces, the truck is compact and maneuverable and has simple and sturdy appearance.

## Comfort

- / The cover is sealed with a good effect of rain resistance.
- / The enlarged brake pedal and appropriate regenerative braking function can effectively reduce the driver's fatigue.
- / The wide-view mast with optimized design is unlikely to obstruct the operator's sight. The enlarged opening size of the fork carriage enables a wider view.



## Maintenance

- / The front-opening hood design makes charging and maintenance easier.
- / The electric control parts, fuse, etc. can be accessed easily and maintained without tools.
- / The side-mounted oil tank facilitates liquid level check and oil addition.

## Stability

- / The center of gravity is moved back by placing the battery at the rear of the truck, it can ensure the longitudinal stability.

## Advancement

- / The Y2 (Enpower controller) series uses 80V voltage system, both the traction and oil pump use permanent magnet synchronous motors, which have high efficiency, strong power and low energy consumption.
- / The controller, oil tank and pump motor are all placed at the front to enable small pipeline length and less energy loss.
- / The high-frequency MOSFET integrated controller ensures smooth and accurate traveling and lifting control, and has excellent speed regulation performance, good performance of electronic control matching the motor, functions of regenerative braking, reverse braking and anti-sliding on ramps, etc., and high safety and reliability.

## Safety

- / The optional lowering lock function can improve the safety greatly when the driver leaves the seat.
- / The soft landing and electronic control lifting buffering (Opt.) are all provide to protect goods effectively.
- / The handbrake can be optionally equipped with an alarm buzzer to prompt the driver to pull up the handbrake before leaving the truck.



The truck is ergonomically designed to provide a good view and a large operating space



Both the traction and oil pump adopt permanent magnet synchronous motors for the Enpower controller



The battery can be removed from the rear enables the battery to be replaced more flexibly (Only for the lead-acid battery)



Multifunctional color screen instrument with graphical interface design is simple and intuitive for operator



Battery is placed at the rear of the truck



### Standard Specification

- / Duplex mast
- / Silent gear pump
- / Multi-function color-screen instrument
- / LED headlight
- / Integral rubber pedal pad
- / Dual multi-way valve
- / Stamping front pedal
- / Integral ABS boarding pedal
- / Integral stamped side panel and hood
- / Soft landing
- / Speed mode selection
- / DC-DC converter
- / Emergency power off switch
- / Reverse buzzer
- / Load sensing steering system
- / Traction pin
- / Rearview mirror

### Options

- / Large-capacity battery
- / Charger
- / Left and right rear view mirrors
- / Reverse armrest
- / Widening or heightening load backrest
- / Forks of other lengths
- / Rear work light
- / Front dual tire
- / Super elastic solid tire
- / Non mark solid tire
- / Triple multi-way valve
- / Quadruple multi-way valve
- / Built-in sideshifter
- / Other attachments
- / Maintenance-free lead carbon battery
- / PVC transparent canopy
- / PVC transparent cover plate for the battery lifting port on the overhead guard
- / Front windshield
- / Cab
- / Warning light
- / Blue light
- / OPS system

Lead-acid specification						
Capacity (Ah/5h)	1.5-mini2t 80V (AEY2)	1.5-mini2t 48V (AED4)	2.0-2.5t 80V (AEY2)	2.0-2.5t 48V (AED4)	3.0-3.5t 80V (AEY2)	3.0-3.5t 80V (AED4)
220	●	—	—	—	—	—
240	○	—	—	—	—	—
300	○	—	●	—	—	—
350	—	—	○	—	—	—
400	—	—	—	—	●	—
420	—	●	—	—	—	—
440	—	—	—	—	○	—
480	—	—	—	—	○	●
500	—	○	—	—	—	—
640	—	—	—	●	—	—
660	—	—	—	○	—	—

● Std. ○ Opt. — Null.

EVE Lithium specification			
Capacity Ah	1.5-mini2t 80V	2.0-2.5t 80V	3.0-3.5t 80V
150	●	●	—
230	○	○	●
280	○	○	○
304	○	○	○
460	—	○	○
560	—	—	○
608	—	—	○

● Std. ○ Opt. — Null.





### 1.5t AE Series Mast Specification

Type	Model	Lifting height	Lowered overall height	Overall height		Free lifting height		Tilting range	Capacity(Mast vertical to ground)	
				Without backrest	With backrest	Without backrest	With backrest		Load center@500mm	
				mm	mm	mm	mm	mm	mm	FWD/BWD
Duplex wide view mast	XPD15M200	2000	1475	2538	2955	135	135	6/12	1500	1500
	XPD15M250	2500	1725	3038	3455	135	135	6/12	1500	1500
	XPD15M270	2700	1825	3238	3655	135	135	6/12	1500	1500
	XPD15M300	3000	1975	3538	3955	135	135	6/12	1500	1500
	XPD15M330	3300	2125	3838	4255	135	135	6/12	1500	1500
	XPD15M350	3500	2225	4038	4455	135	135	6/12	1500	1500
	XPD15M360	3600	2325	4138	4555	135	135	6/12	1500	1500
	XPD15M370	3700	2375	4238	4655	135	135	6/12	1500	1500
	XPD15M400	4000	2575	4538	4955	135	135	6/12	1500	1500
	XPD15M430	4300	2725	4838	5255	135	135	6/6	1500	1500
	XPD15M450	4500	2825	5038	5455	135	135	6/6	1500	1500
	XPD15M480	4800	2975	5338	5755	135	135	6/6	1400	1500
XPD15M500	5000	3075	5538	5955	135	135	6/6	1350	1400	
Duplex full-free mast	XPD15U200	2000	1490	2559	2945	931	545	6/6	1500	1500
	XPD15U250	2500	1740	3059	3445	1181	795	6/12	1500	1500
	XPD15U270	2700	1840	3259	3645	1281	895	6/12	1500	1500
	XPD15U300	3000	1990	3559	3945	1431	1045	6/12	1500	1500
	XPD15U330	3300	2140	3859	4245	1581	1195	6/12	1500	1500
	XPD15U350	3500	2240	4059	4445	1681	1295	6/12	1500	1500
	XPD15U360	3600	2290	4159	4545	1731	1345	6/12	1500	1500
	XPD15U370	3700	2340	4259	4645	1781	1395	6/12	1500	1500
Triplex full-free mast	XPD15U400	4000	2540	4559	4945	1981	1595	6/12	1500	1500
	XPD15N400	4000	1940	4569	4955	1381	995	6/6	1500	1500
	XPD15N430	4300	2040	4869	5255	1481	1095	6/6	1500	1500
	XPD15N450	4500	2090	5069	5455	1531	1145	6/6	1500	1500
	XPD15N480	4800	2240	5369	5755	1681	1295	6/6	1400	1500
	XPD15N500	5000	2340	5569	5955	1781	1395	6/6	1400	1450
	XPD15N550	5500	2540	6069	6455	1981	1595	3/6	1250	1350
	XPD15N600	6000	2790	6600	6955	2200	1845	3/6	1100	1150

## 1.8t AE Series Mast Specification

Type	Model	Lifting height	Lowered overall height	Overall height		Free lifting height		Tilting range	Capacity(Mast vertical to ground)			
				Without backrest	With backrest	Without backrest	With backrest	FWD/BWD	Load center@500mm		1.8t	1.8t
									Single Tire	Double Tire		
				mm	mm	mm	mm	(°)	kg	kg		
Duplex wide view mast	XPD18M200	2000	1475	2648	2955	135	135	6/12	1800	1800		
	XPD18M250	2500	1725	3148	3455	135	135	6/12	1800	1800		
	XPD18M270	2700	1825	3348	3655	135	135	6/12	1800	1800		
	XPD18M300	3000	1975	3648	3955	135	135	6/12	1800	1800		
	XPD18M330	3300	2125	3948	4255	135	135	6/12	1800	1800		
	XPD18M350	3500	2225	4148	4455	135	135	6/12	1800	1800		
	XPD18M360	3600	2325	4248	4555	135	135	6/12	1800	1800		
	XPD18M370	3700	2375	4348	4655	135	135	6/12	1800	1800		
	XPD18M400	4000	2575	4648	4955	135	135	6/12	1800	1800		
	XPD18M430	4300	2725	4948	5255	135	135	6/6	1700	1750		
	XPD18M450	4500	2825	5148	5455	135	135	6/6	1650	1700		
	XPD18M480	4800	2975	5448	5755	135	135	6/6	1600	1650		
	XPD18M500	5000	3075	5648	5955	135	135	6/6	1550	1600		
	Duplex full-free mast	XPD18U200	2000	1490	2669	2945	821	545	6/6	1800	1800	
XPD18U250		2500	1740	3169	3445	1071	795	6/12	1800	1800		
XPD18U270		2700	1840	3369	3645	1171	895	6/12	1800	1800		
XPD18U300		3000	1990	3669	3945	1321	1045	6/12	1800	1800		
XPD18U330		3300	2140	3969	4245	1471	1195	6/12	1800	1800		
XPD18U350		3500	2240	4169	4445	1571	1295	6/12	1800	1800		
XPD18U360		3600	2290	4269	4545	1621	1345	6/12	1800	1800		
XPD18U370		3700	2340	4369	4645	1671	1395	6/12	1800	1800		
Triplex full-free mast	XPD18N430	4300	2040	4979	5255	1371	1095	6/6	1650	1800		
	XPD18N450	4500	2090	5179	5455	1421	1145	6/6	1650	1750		
	XPD18N480	4800	2240	5479	5755	1571	1295	6/6	1600	1650		
	XPD18N500	5000	2340	5679	5955	1671	1395	6/6	1550	1600		
	XPD18N550	5500	2540	6179	6455	1871	1595	3/6	1500	1550		
	XPD18N600	6000	2790	6679	6955	2121	1845	3/6	1300	1400		

## 2.0t/2.5t AE Series Mast Specification

Type	Model	Lifting height	Lowered overall height	Overall height		Free lifting height		Tilting range	Capacity(Mast vertical to ground)					
				Without backrest	With backrest	Without backrest	With backrest	FWD/BWD	Load center@500mm		2.0t	2.5t	2.0t	2.5t
									Single Tire	Double Tire				
				mm	mm	mm	mm	(°)	kg	kg	kg	kg		
Duplex wide view mast	XPD25M200	2000	1501	2626	3046	140	140	6/6	2000	2500	2000	2500		
	XPD25M250	2500	1751	3126	3546	140	140	6/12	2000	2500	2000	2500		
	XPD25M270	2700	1851	3326	3746	140	140	6/12	2000	2500	2000	2500		
	XPD25M300	3000	2001	3626	4046	140	140	6/12	2000	2500	2000	2500		
	XPD25M330	3300	2151	3926	4346	140	140	6/12	2000	2500	2000	2500		
	XPD25M350	3500	2251	4126	4546	140	140	6/12	2000	2500	2000	2500		
	XPD25M360	3600	2351	4226	4646	140	140	6/12	2000	2500	2000	2500		
	XPD25M370	3700	2401	4326	4746	140	140	6/12	2000	2500	2000	2500		
	XPD25M400	4000	2601	4626	5046	140	140	6/12	2000	2500	2000	2500		
	XPD25M430	4300	2751	4926	5346	140	140	6/6	2000	2500	2000	2500		
	XPD25M450	4500	2851	5126	5546	140	140	6/6	2000	2450	2000	2500		
	XPD25M470	4700	2951	5326	5746	140	140	6/6	1950	2350	2000	2450		
	XPD25M480	4800	3001	5426	5846	140	140	6/6	1950	2350	2000	2450		
	XPD25M500	5000	3101	5626	6046	140	140	6/6	1850	2300	1950	2350		
XPD25M550	5500	3351	6126	6546	140	140	3/6	1750	2150	1900	2200			
XPD25M600	6000	3601	6626	7046	140	140	3/6	1550	1900	1800	2000			
Duplex full-free mast	XPD25U200	2000	1516	2749	3046	842	470	6/6	2000	2500	2000	2500		
	XPD25U250	2500	1766	3173.5	3546	1092	720	6/12	2000	2500	2000	2500		
	XPD25U270	2700	1866	3373.5	3746	1192	820	6/12	2000	2500	2000	2500		
	XPD25U300	3000	2016	3673.5	4046	1342	970	6/12	2000	2500	2000	2500		
	XPD25U330	3300	2166	3973.5	4346	1492	1120	6/12	2000	2500	2000	2500		
	XPD25U350	3500	2266	4173.5	4546	1592	1220	6/12	2000	2500	2000	2500		
	XPD25U360	3600	2316	4273.5	4646	1642	1270	6/12	2000	2500	2000	2500		
	XPD25U370	3700	2366	4373.5	4746	1692	1320	6/12	2000	2500	2000	2500		
Triplex full-free mast	XPD25N400	4000	1966	4670.5	5046	1195	920	6/6	2000	2500	2000	2500		
	XPD25N430	4300	2066	4970.5	5346	1295	1020	6/6	2000	2450	2000	2500		
	XPD25N450	4500	2116	5170.5	5546	1345	1070	6/6	2000	2350	2000	2450		
	XPD25N470	4700	2216	5370.5	5746	1445	1170	6/6	1950	2250	2000	2350		
	XPD25N480	4800	2266	5470.5	5846	1495	1220	6/6	1950	2250	2000	2350		
	XPD25N500	5000	2366	5670.5	6046	1595	1320	6/6	1850	2150	1950	2250		
	XPD25N550	5500	2566	6170.5	6546	1795	1520	3/6	1750	2050	1900	2100		
	XPD25N600	6000	2816	6670.5	7046	2045	1770	3/6	1550	1850	1800	1950		
	XPD25N650	6500	3016	7170.5	7546	2245	1970	3/6	/	/	1550	1800		
	XPD25N700	7000	3266	7766	8046	2695	2220	3/6	/	/	1150	1450		

## Short Wheelbase 2.0t AE Series Mast Specification

Type	Model	Lifting height	Lowered overall height	Overall height		Free lifting height		Tilting range	Capacity(Mast vertical to ground)					
				Without backrest	With backrest	Without backrest	With backrest	FWD/BWD	Load center@500mm		3.0t	3.5t	3.0t	3.5t
									Single Tire	Double Tire				
				mm	mm	mm	mm	(°)	kg	kg				
Duplex wide view mast	APYX20M200	2000	1475	2648	2955	140	140	6/12	2000	2000				
	APYX20M250	2500	1725	3148	3455	140	140	6/12	2000	2000				
	APYX20M270	2700	1825	3348	3655	140	140	6/12	2000	2000				
	APYX20M300	3000	1975	3648	3955	140	140	6/12	2000	2000				
	APYX20M330	3300	2125	3948	4255	140	140	6/12	2000	2000				
	APYX20M350	3500	2225	4148	4455	140	140	6/12	2000	2000				
	APYX20M360	3600	2325	4248	4555	140	140	6/12	2000	2000				
	APYX20M370	3700	2375	4348	4655	140	140	6/12	2000	2000				
	APYX20M400	4000	2575	4648	4955	140	140	6/12	2000	2000				
	APYX20M430	4300	2725	4948	5255	140	140	6/6	1900	2000				
	APYX20M450	4500	2825	5148	5455	140	140	6/6	1850	1900				
	APYX20M480	4800	2975	5448	5755	140	140	6/6	1800	1850				
	APYX20M500	5000	3075	5648	5955	140	140	6/6	1700	1750				
	Duplex full-free mast	APYX20U200	2000	1490	2669	2945	826	550	6/6	2000	2000			
APYX20U250		2500	1740	3169	3445	1076	800	6/12	2000	2000				
APYX20U270		2700	1840	3369	3645	1176	900	6/12	2000	2000				
APYX20U300		3000	1990	3669	3945	1326	1050	6/12	2000	2000				
APYX20U330		3300	2140	3969	4245	1476	1200	6/12	2000	2000				
APYX20U350		3500	2240	4169	4445	1576	1300	6/12	2000	2000				
APYX20U360		3600	2290	4269	4545	1626	1350	6/12	2000	2000				
APYX20U370		3700	2340	4369	4645	1676	1400	6/12	2000	2000				
Triplex full-free mast	APYX20N430	4300	2040	4979	5255	1376	1100	6/6	1850	1950				
	APYX20N450	4500	2090	5179	5455	1426	1150	6/6	1800	1900				
	APYX20N480	4800	2240	5479	5755	1576	1300	6/6	1750	1850				
	APYX20N500	5000	2340	5679	5955	1676	1400	6/6	1700	1800				
	APYX20N550	5500	2540	6179	6455	1876	1600	3/6	1650	1750				
	APYX20N600	6000	2790	6679	6955	2126	1850	3/6	1450	1500				

## 3.0t/3.5t AE Series Mast Specification

Type	Model	Lifting height	Lowered overall height	Overall height		Free lifting height		Tilting range	Capacity(Mast vertical to ground)					
				Without backrest	With backrest	Without backrest	With backrest	FWD/BWD	Load center@500mm		3.0t	3.5t	3.0t	3.5t
									Single Tire	Double Tire				
				mm	mm	mm	mm	(°)	kg	kg	kg	kg		
Duplex wide view mast	APY35M200	2000	1665	2856	3159	145	150	6/6	3000	3500	3000	3500		
	APY35M250	2500	1915	3356	3659	145	150	6/12	3000	3500	3000	3500		
	APY35M270	27												

# AE Series Lead-acid Battery Forklift

		Manufacturer (abbreviation)	HANGCHA GROUP CO.,LTD.														
Distinguishing mark	1.1	Manufacturers type designation	CPD15-AEY2 CPD15-AEY2-F2	CPD15-AED4*	CPD18-AEY2 CPD18-AEY2-F2	CPD18-AED4*	CPD20-AEY2	CPD20-AED4*	CPD20-AEY2 CPD20-AEY2-F2	CPD20-AED4*	CPD25-AEY2 CPD25-AEY2-F2	CPD25-AED4*	CPD30-AEY2 CPD30-AEY2-F2	CPD30-AED4*	CPD35-AEY2 CPD35-AEY2-F2	CPD35-AED4*	
		1.2	Drive: electric (battery or mains), diesel, petrol, fuel gas	Electric		Electric		Electric		Electric		Electric		Electric		Electric	
		1.3	Operator type: hand, pedestrian, standing, seated, order-picker	Seated		Seated		Seated		Seated		Seated		Seated		Seated	
		1.4	Load capacity/rated load	Q (kg) 1500		1800		2000		2000		2500		3000		3500	
		1.5	Load centre distance	c (mm) 500		500		500		500		500		500		500	
		1.6	Load distance, centre of drive axle to fork	x (mm) 405		410		415		444		444		477.5		482.5	
		1.7	Wheelbase	y (mm) 1430		1430		1430		1520		1520		1650		1650	
	Weight	2.1	Service Weight	kg 2760 2890		3040 3040		3300 3270		3480 3660		4000 3950		4430 4650		4950 5050	
2.2		Axle loading, laden front/rear	kg 3800/500 3790/600		4290/550 4310/530		4700/600 4730/540		4820/660 4880/780		5800/700 5780/660		6630/800 6730/920		7590/860 7650/900		
2.3		Axle loading, unladen front/rear	kg 1370/1430 1330/1560		1350/1560 1360/1680		1420/1880 1450/1820		1580/1900 1640/2020		1770/2230 1730/2220		1890/2540 1950/2700		2030/2920 2100/2950		
Tyres, chassis	3.1	Tyres: solid rubber, superelastic, pneumatic, polyurethane	Pneumatic		Pneumatic		Pneumatic		Pneumatic		Pneumatic		Pneumatic		Pneumatic		
	3.2	Tyre size, front	6.00-9NHS-10PR		21X8-9-16PR		21X8-9-16PR		23X9-10-16PR		23X9-10-16PR		28X9-15-14PR		28X9-15-14PR		
	3.3	Tyre size, rear	5.00-8NHS-10PR		5.00-8NHS-10PR		5.00-8NHS-10PR		18X7-8-14PR		18X7-8-14PR		18X7-8-16PR		18X7-8-16PR		
	3.4	Wheels, number front rear (X = driven wheels)	2x/2		2x/2		2x/2		2x/2		2x/2		2x/2		2x/2		
	3.5	Tread, front	b10 (mm) 888		938		938		1058		1058		1009		1009		
	3.6	Tread, rear	b11 (mm) 897.5		897.5		897.5		960		960		960		960		
Dimensions	4.1	Tilt of mast/fork carriage forward/backward	α/β(°) 6/12		6/12		6/12		6/12		6/12		6/12		6/12		
	4.2	Height, mast lowered	h1 (mm) 1975		1975		1975		2001		2001		2165		2165		
	4.3	Free lift	h2 (mm) 135		135		140		140		140		145		145		
	4.4	Lift	h3 (mm) 3000		3000		3000		3000		3000		3000		3000		
	4.5	Height, mast extended	h4 (mm) 3955		3955		3955		4040		4040		4159		4159		
	4.6	Height of overhead guard STD.	h6 (mm) 2080		2080		2080		2100		2100		2178		2178		
	4.7	Seat height/stand height	h7 (mm) 1090		1090		1090		1115		1115		1182		1182		
	4.8	Coupling height	h10 (mm) 285		285		285		308		308		317		317		
	4.9	Overall length	l1 (mm) 3125		3130		3135		3430		3430		3657		3662		
	4.10	Length to face of forks	l2 (mm) 2205		2210		2215		2360		2360		2587		2592		
	4.11	Overall width(single/dual front tyres)	b1 (mm) 1120/1428		1138/1428		1138/1428		1260/1783		1260/1783		1241/1736		1241/1736		
	4.12	Fork dimensions	s/e/l (mm) 35×100×920		35×100×920		40×100×920		40×122×1070		40×122×1070		45×122×1070		50×122×1070		
	4.13	Fork carriage DIN 15173 --- ISO 2328, class/type A,B	ISO 2328 2A		ISO 2328 2A		ISO 2328 2A		ISO 2328 2A		ISO 2328 2A		ISO 2328 3A		ISO 2328 3A		
	4.14	Fork-carriage width	b3 (mm) 1000		1000		1000		1100		1100		1100		1100		
	4.15	Distance between fork-arms	b5 (mm) 240/1000		240/1000		240/1000		290/1100		290/1100		290/1100		290/1100		
	4.16	Ground clearance, laden, below mast	m1 (mm) 95		95		95		120		120		135		135		
4.17	Ground clearance, centre of wheelbase	m2 (mm) 100		100		100		125		125		134		134			
4.18	Aisle width for pallets 1000 × 1200 crossways	Ast (mm) 3655		3660		3660		3794		3794		4057.5		4062.5			
4.19	Aisle width for pallets 800 x 1200 lengthways	Ast (mm) 3855		3860		3860		3994		3994		4257.5		4262.5			
4.20	Turning radius	Wa (mm) 2050		2050		2050		2150		2150		2380		2380			
Performance data	5.1	Travel speed, laden/unladen	km/h 13.5/14		13.5/14		13.5/14		14/14		14/14		14/14		14/14		
	5.2	Lift speed, laden/unladen	mm/s 280/430		280/430		280/430		280/430		280/430		280/400		280/400		
	5.3	Lowering speed, laden/unladen	mm/s 500/430		500/440		500/440		500/430		500/440		470/420		470/420		
	5.5	Max. Drawbar pull, laden/unladen	N 7000		7000		7000		11000		11000		13000		13000		
	5.7	Max. gradeability, laden/unladen	% 15/15		15/15		15/15		15/15		15/15		15/15		15/13	15/15	
	5.9	Service brake	Hydraulic		Hydraulic		Hydraulic		Hydraulic		Hydraulic		Hydraulic		Hydraulic		
	5.10	Parking brake	Mechanical		Mechanical		Mechanical		Mechanical		Mechanical		Mechanical		Mechanical		
Electric-engine	6.1	Drive motor rating S2 60 min	kW 6AC 8AC		6AC 8AC		6AC 8AC		9AC 11AC		9AC 11AC		11AC 15AC		11AC 15AC		
	6.2	Lift motor rating at S3 15%	kW 5AC 8.6AC		5AC 8.6AC		5AC 8.6AC		7AC 8.6AC		7AC 8.6AC		8AC 10AC		8AC 10AC		
	6.3	Battery acc. to DIN 43 531/35/36 A,B,C, no	no		no		no		no		no		no		no		
	6.4	Battery voltage, nominal capacity K5	V/Ah 80/220 48/420		80/220 48/420		80/220 48/420		80/300 48/640		80/300 48/640		80/400 80/480		80/400 80/480		
	6.5	Battery weight	kg 700 735		700 735		700 735		880 1000		880 1000		1080 1250		1080 1250		
	6.6	Battery dimensions	mm 812x920x483		812x920x483		812x920x483		852×1035×483 852x1035x513		852×1035×483 852x1035x513		825×1165×543		825×1165×543		
7.1	Type of drive control	MOSFET/AC		MOSFET/AC		MOSFET/AC		MOSFET/AC		MOSFET/AC		MOSFET/AC		MOSFET/AC			
Addition data	8.1		18.5		18.5		18.5		18.5		18.5		18.5		18.5		
	8.4	Towing coupling, type DIN	MPa Φ24 Pin		Φ24 Pin		Φ24 Pin		Φ24 Pin		Φ24 Pin		Φ24 Pin		Φ24 Pin		

Note: \* CE model  
 ❄️ F2: Means the cold storage truck model F2 are suitable for use in cold storage environments down to -30 °C.

# AE Series Lithium Battery Forklift

		HANGCHA GROUP CO.,LTD.															
Distinguishing mark	1.1	Manufacturers type designation	CPD15-AEY2-I* CPD15-AEY2-IF2	CPD15-AED4-I*	CPD18-AEY2-I* CPD18-AEY2-IF2	CPD18-AED4-I*	CPD20-AEY2-I*	CPD20-AEXD4-I*	CPD20-AEY2-I* CPD20-AEY2-IF2	CPD20-AED4-I*	CPD25-AEY2-I* CPD25-AEY2-IF2	CPD25-AED4-I*	CPD30-AEY2-I* CPD30-AEY2-IF2	CPD30-AED4-I*	CPD35-AEY2-I* CPD35-AEY2-IF2	CPD35-AED4-I*	
	1.2	Drive: electric (battery or mains), diesel, petrol, fuel gas	Electric		Electric		Electric		Electric		Electric		Electric		Electric		
	1.3	Operator type: hand, pedestrian, standing, seated, order-picker	Seated		Seated		Seated		Seated		Seated		Seated		Seated		
	1.4	Load capacity/rated load	Q (kg)	1500	1800	2000	2000	2500	3000	3500							
	1.5	Load centre distance	c (mm)	500	500	500	500	500	500	500							
	1.6	Load distance, centre of drive axle to fork	x (mm)	405	410	415	444	444	477.5	482.5							
	1.7	Wheelbase	y (mm)	1430	1430	1430	1520	1520	1650	1650							
Weight	2.1	Service Weight	kg	2630	2700	2910	2850	3150	3080	3230	3465	3750	3750	4230	4445	4750	4765
	2.2	Axle loading, laden front/rear	kg	3650/480	3600/600	4190/520	4110/540	4600/550	4530/550	4630/600	4715/750	5620/630	5600/650	6470/760	6560/885	7430/820	7445/820
	2.3	Axle loading, unladen front/rear	kg	1210/1420	1150/1550	1240/1670	1180/1670	1360/1790	1280/1800	1390/1840	1475/1990	1560/2190	1550/2200	1680/2550	1785/2660	1850/2900	1855/2910
Tyres, chassis	3.1	Tyres: solid rubber, superelastic, pneumatic, polyurethane	Pneumatic		Pneumatic		Pneumatic		Pneumatic		Pneumatic		Pneumatic		Pneumatic		
	3.2	Tyre size, front	6.00-9NHS-10PR		21x8-9-16PR		21x8-9-16PR		23x9-10-16PR		23x9-10-16PR		28x9-15-14PR		28x9-15-14PR		
	3.3	Tyre size, rear	5.00-8NHS-10PR		5.00-8NHS-10PR		5.00-8NHS-10PR		18x7-8-14PR		18x7-8-14PR		18x7-8-16PR		18x7-8-16PR		
	3.4	Wheels, number front rear (X = driven wheels)	2x/2		2x/2		2x/2		2x/2		2x/2		2x/2		2x/2		
	3.5	Tread, front	b <sub>10</sub> (mm)	888	938	938	1058	1058	1009	1009							
	3.6	Tread, rear	b <sub>11</sub> (mm)	897.5	897.5	897.5	960	960	960	960							
Dimensions	4.1	Tilt of mast/fork carriage forward/backward	α/β(°)	6/12	6/12	6/12	6/12	6/12	6/12	6/12	6/12	6/12	6/12	6/12	6/12	6/12	
	4.2	Height, mast lowered	h <sub>1</sub> (mm)	1975	1975	1975	2001	2001	2165	2165							
	4.3	Free lift	h <sub>2</sub> (mm)	135	135	135	140	140	145	145							
	4.4	Lift	h <sub>3</sub> (mm)	3000	3000	3000	3000	3000	3000	3000							
	4.5	Height, mast extended	h <sub>4</sub> (mm)	3955	3955	3955	4040	4040	4159	4159							
	4.6	Height of overhead guard STD.	h <sub>6</sub> (mm)	2080	2080	2080	2100	2100	2178	2178							
	4.7	Seat height/stand height	h <sub>7</sub> (mm)	1090	1090	1090	1115	1115	1182	1182							
	4.8	Coupling height	h <sub>10</sub> (mm)	285	285	285	308	308	317	317							
	4.9	Overall length	l <sub>1</sub> (mm)	3125	3130	3135	3430	3430	3657	3662							
	4.10	Length to face of forks	l <sub>2</sub> (mm)	2205	2210	2215	2360	2360	2587	2592							
	4.11	Overall width(single/dual front tyres)	b <sub>1</sub> (mm)	1120/1428	1120/1428	1120/1428	1260/1783	1260/1783	1241/1736	1241/1736							
	4.12	Fork dimensions	s/e/l (mm)	35×100×920	35×100×920	40×100×920	40x122x1070	40x122x1070	45x122x1070	50x122x1070							
	4.13	Fork carriage DIN 15173 --- ISO 2328, class/type A,B		ISO 2328 2A	ISO 2328 2A	ISO 2328 2A	ISO 2328 2A	ISO 2328 2A	ISO 2328 2A	ISO 2328 3A	ISO 2328 3A						
	4.14	Fork-carriage width	b <sub>3</sub> (mm)	1000	1000	1000	1100	1100	1100	1100							
	4.15	Distance between fork-arms	b <sub>5</sub> (mm)	240/1000	240/1000	240/1000	290/1100	290/1100	290/1100	290/1100							
	4.16	Ground clearance, laden, below mast	m <sub>1</sub> (mm)	95	95	95	120	120	135	135							
	4.17	Ground clearance, centre of wheelbase	m <sub>2</sub> (mm)	100	100	100	125	125	134	134							
	4.18	Aisle width for pallets 1000 × 1200 crossways	A <sub>st</sub> (mm)	3655	3660	3660	3794	3794	4057.5	4062.5							
	4.19	Aisle width for pallets 800 × 1200 lengthways	A <sub>st</sub> (mm)	3855	3860	3860	3994	3994	4257.5	4262.5							
	4.20	Turning radius	W <sub>a</sub> (mm)	2050	2050	2050	2150	2150	2380	2380							
Performance data	5.1	Travel speed, laden/unladen	km/h	13.5/14	13.5/14	13.5/14	14/14	14/14	14/14	14/14							
	5.2	Lift speed, laden/unladen	mm/s	280/430	280/430	280/430	280/430	280/430	280/400	280/400							
	5.3	Lowering speed, laden/unladen	mm/s	500/430	500/440	500/440	500/430	500/440	470/420	470/420							
	5.5	Max. Drawbar pull, laden/unladen	N	7000	7000	7000	11000	11000	13000	13000							
	5.7	Max. gradeability, laden/unladen	%	15/15	15/15	15/15	15/15	15/15	15/15	15/15							
	5.9	Service brake		Hydraulic	Hydraulic	Hydraulic	Hydraulic	Hydraulic	Hydraulic	Hydraulic							
	5.10	Parking brake		Mechanical	Mechanical	Mechanical	Mechanical	Mechanical	Mechanical	Mechanical							
Electric-engine	6.1	Drive motor rating S2 60 min	kW	6AC	8AC	6AC	8AC	6AC	8AC	9AC	11AC	9AC	11AC	11AC	15AC	11AC	15AC
	6.2	Lift motor rating at S3 15%	kW	5AC	8.6AC	5AC	8.6AC	5AC	8.6AC	7AC	8.6AC	7AC	8.6AC	8AC	10AC	8AC	10AC
	6.4	Battery voltage, nominal capacity K5	V/Ah	80/150	80/150	80/150	80/150	80/150	80/230	80/230							
	6.5	Battery weight	kg	≥150kg	≥150kg	≥150kg	230	230	270	270							
Addition data	7.1	Type of drive control		MOSFET/AC	MOSFET/AC	MOSFET/AC	MOSFET/AC	MOSFET/AC	MOSFET/AC	MOSFET/AC	MOSFET/AC	MOSFET/AC	MOSFET/AC	MOSFET/AC	MOSFET/AC		
	8.1		MPa	18.5	18.5	18.5	18.5	18.5	18.5								
	8.4	Towing coupling, type DIN		Φ24 Pin	Φ24 Pin	Φ24 Pin	Φ24 Pin	Φ24 Pin	Φ24 Pin								

Note: \* CE model  
 ❄️ F2: Means the cold storage truck model F2 are suitable for use in cold storage environments down to -30 °C.

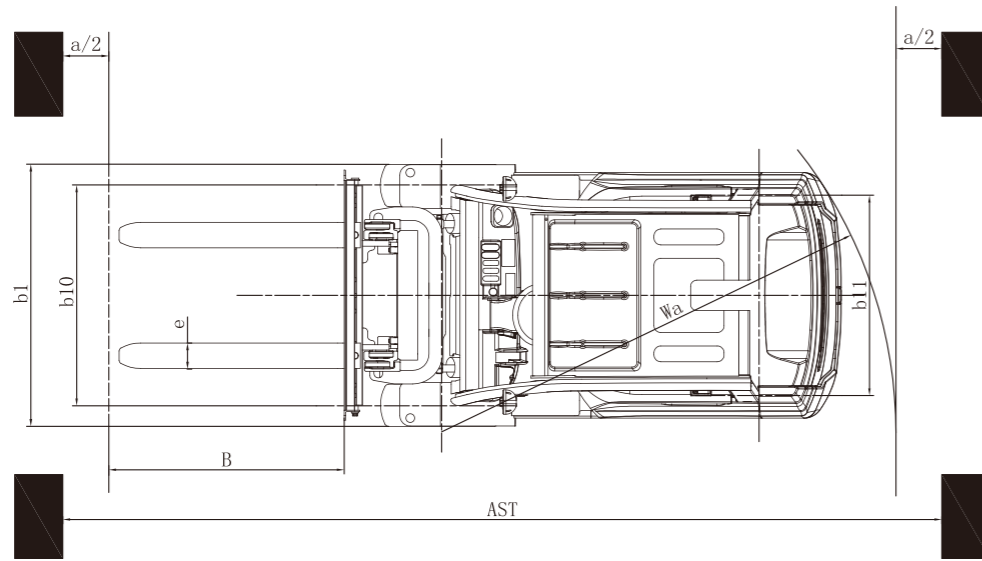
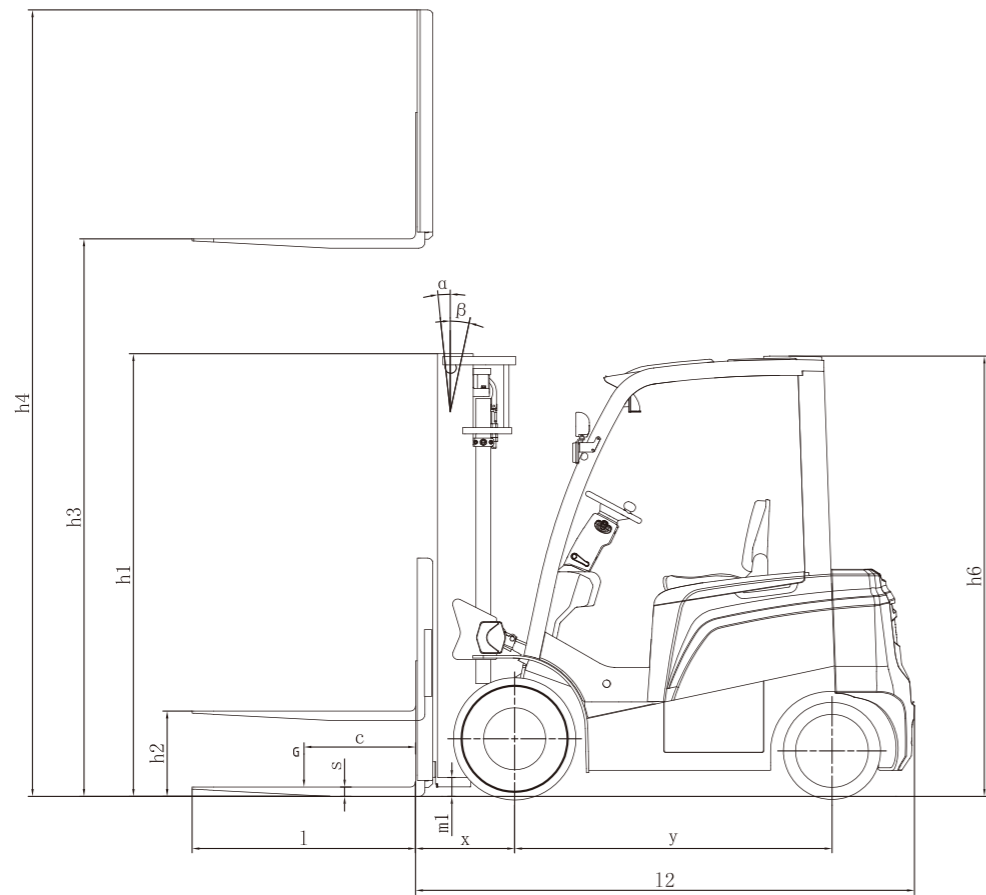

$AST = a + W_a + x + B \quad a: (200mm)$

