

Appearance

/ The worldwide popular, great-circle, streamlined surface modeling is applied, with smooth, beautiful, and elegant appearance.

Stability

/ The broad and solid chassis and steady reach mechanism, as well as the drive unit that is fixed at center, realize low gravity center, and guarantee sufficient stability of the truck.

Flexibility

/ The driving system that is located at rear part of chassis uses EPS (Electric Power Steering) technology, features low-speed and large torque. The 180-degree steering mode of standard configuration, make the truck flexible and convenient, and allow it turn easily even in confined space.

Comfort

- / Operating levers of ergonomic design, integrated console, all important operating parts are within the reach of your hands.
- / The mast of optimized design with wide view avoids blocking the sight of the operator, and large size of the fork shelf offers wider view.
- / The seat can be adjusted forward and backward, also with the function of vibration reduction.
- / The truck body with increased width and height offers larger operating space for hands and legs of the operator.
- / The new designed overhead guard structure allows the operator to observe the movement of load more clearly.

Maintenance

- / The fully-opened cover provides easy maintenance for motor, controller and transmission, braking, and hydraulic systems.
- / The battery compartment can be removed forward, so replacement or maintenance is very easy.



Wider view OHG

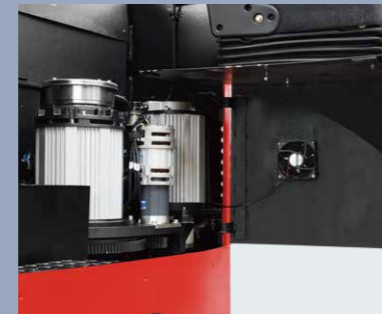

High-performance motor



Comfortable and convenient seat



Instrument can display the steering angle and direction Synchronously



The steering wheel is extensible, so the operator can choose the best driving position



HANGCHA GROUP CO., LTD.

Factory site: 666 Xiangfu Road, Hangzhou, Zhejiang, China (311305)

Tel: +86-571-88926735 88926755
Fax: +86-571-88926789 88132890

sales@hcforklift.com
www.hcforklift.com



Follow us on Facebook



Follow us on YouTube



Follow us on WeChat



Download "Hangcha Forklift" App



ISO45001



ISO14001



ISO9001



HANGCHA trucks conform to the European Safety Requirements.

2025 VERSION 3/COPYRIGHT 2025/09

HANGCHA GROUP CO., LTD. reserves the right to make any changes without notice concerning colors, equipment, or specifications detailed in this brochure, or to discontinue individual models. The colors of trucks, delivered may differ slightly from those in brochures.



A Series Reach Truck

with capacities of 1,200 to 2,000kg

The World of Hangcha



LET THE LITHIUM POWER UNLEASH



INNOVATIVE SOLUTIONS NEW POWER NOW

- / We use square lithium iron phosphate batteries and modules used in large quantities by commercial vehicles in mature economies.
- / The module uses an aluminum alloy frame which is sturdy, lightweight and with excellent heat dissipation.
- / Safe and effective: Charging efficiency as high as 98%, thermal runaway temperature 600 °C or above.
- / Adapted to low temperatures: Comes standard with an electrical heating feature, ensuring normal operation in low temperatures.
- / Quick charging: 2 hours full charge, economic use of each break.
- / Long-working: 4000 charging cycles, capacity retention greater than 75%.
- / Maintenance-free: Battery does not require manual maintenance.
- / Green and clean: Pollution-free, zero emissions.

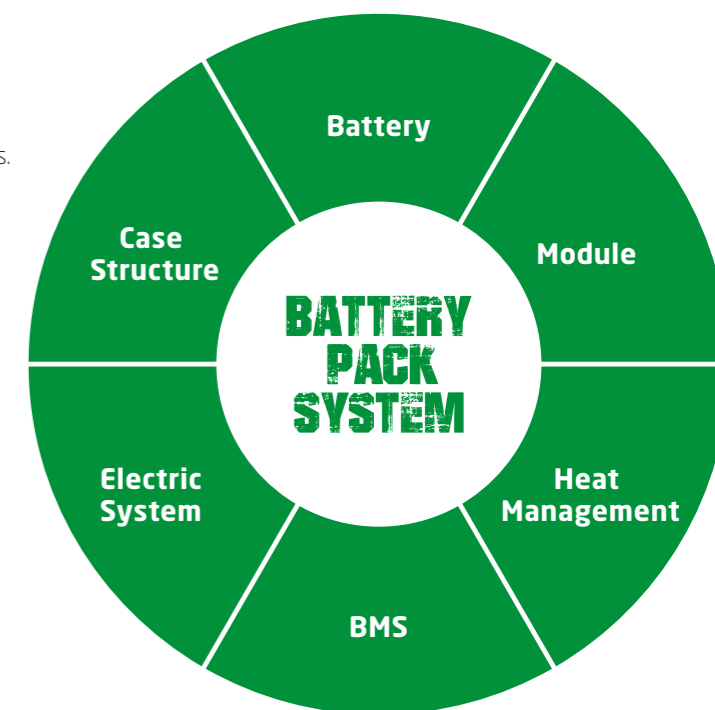

Li-Ion
2 hours
100%

Lead-acid batteries
8-10 hours 100%

Rapid charging and opportunity charging ensure continuous availability of vehicles.

Li-Ion powered forklifts are always available. They allow for fast full charging or boost charging (100 % charge in 2 hours). They are maintenance free and do not require a battery change when used for multi-shift operations.

Li-Ion Battery Pack specification

Type		CQD16-AC5-1* / CQD16-AC5-IF2	CQD18-AC5-1* / CQD18-AC5-IF2	CQD20-AC5-1* / CQD20-AC5-IF2
Li-Ion battery	V/Ah	80/302	80/302	80/302
Option capacity	V/Ah	80/280(EVE), 80/304(EVE), 80/460(EVE)		

* CE model

* F2: Means the cold storage truck model F2 are suitable for use in cold storage environments down to -30 °C.

LI-ION
TECHNOLOGY

HANGCHA provides Li-Ion battery (LiFePO4) with 6 years or 12000 hours warranty.

6 YEARS
WARRANTY

A Series Reach Truck

The reach truck is suitable for working in narrow passageway and confined space, with high lifting and load capacity, and is the ideal tool for loading, unloading, handling, and stacking in warehouse, supermarket, and workshop.

**Environment/
Efficiency/
Economy**



Reliability & Safety

- / Major electrical components such as controller, contactor, and power plug are all of foreign famous brands.
- / As a standard configuration, the emergency power off switch complies with European safety standards.
- / Electronic and hydraulic overload protection, power-failure lock up of fork(optional), and safe pedal.

Benefits of the AC Power System

- / The AC power system has high efficiency, full protection functions, powerful acceleration performance, sensitive and fast steering.
- / The brushless, maintenance-free AC motor has longer service life, and lower maintenance cost.

Advance

- / Three-phase AC technology is applied for driving and steering, AC technologies are available for lifting. Full AC power system has higher efficiency, and is free maintenance.
- / The MOSFET integrated controller guarantees smooth and accurate control on driving, steering and lifting, as well as superior speed regulation performance, with regenerative braking, reverse braking, anti-slipping on slope and other functions, resulting in more efficient, safer operations.
- / The LCD battery condition meter, timer, fault self-diagnosis meter, and display can not only display most important operating data, driving direction and location of driving wheels that are interactive with steering, but also realize accurate display in harsh environment.
- / The full AC truck is equipped with non-backlash, high pressure resistant, silent gear pump.
- / The full AC truck is equipped with stepless speed regulation for lifting operation, the mast lift top buffering, mast move forward/backward buffering, travelling speed and speed of mast move forward/backward will slow down automatically when the mast lifting high position, all of this can greatly improve the stability of the truck.
- / The CANBUS communication technology is applied to monitor motor speed, temperature, and other information in real time, realizing closed-loop control.
- / The truck has a triple braking mechanism, i.e. electronic braking (reverse regenerative braking), front wheel hydraulic braking, and electromagnetic parking braking.



High-performance Mast

- / The operator has wider view in the load direction.
- / Built-in sideshifter and fork tilting are standard configuration.
- / The mast made with imported steel channels and compact structural design has a maximum lifting height: 12500mm.
- / Height monitoring and lifting height limitation system are optional.

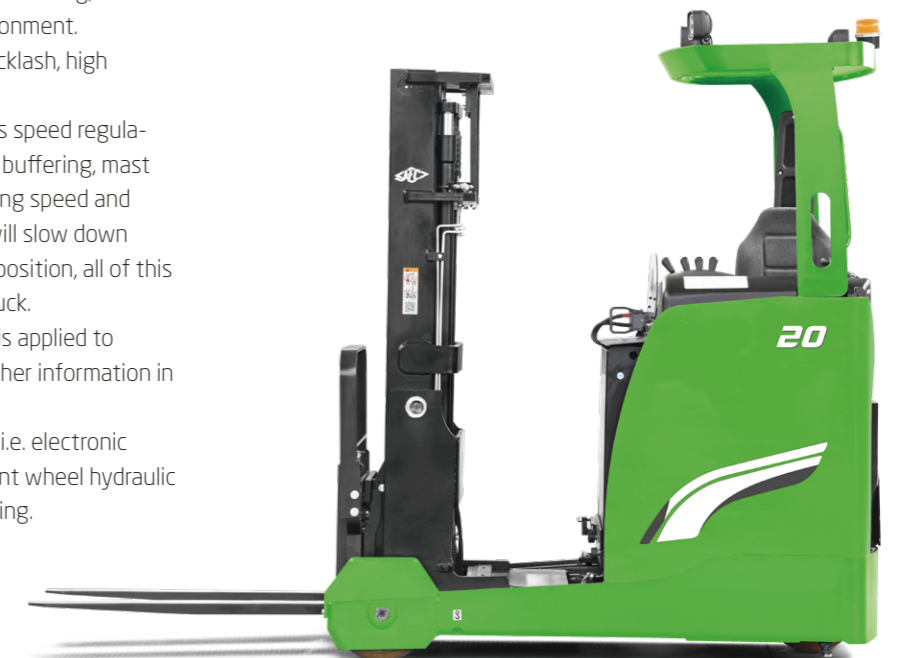



Battery can be removed forward, easy for maintenance

Traction device

A Series Reach Truck

Distinguishing mark	HANGCHA GROUP CO.,LTD.							
		QD12-AC5*	QD14-AC5*	QD16-AC5*	QD18-AC5*	QD20-AC5*		
1.1	Manufacturer							
1.2	Manufacturer's type designation	QD12-AC5-F2	QD14-AC5-F2	QD16-AC5-F2	QD18-AC5-F2	QD20-AC5-F2		
1.3	Drive: electric (battery or mains), diesel, petrol, fuel gas	electric	electric	electric	electric	electric		
1.5	Rated capacity/rated load	Q (kg)	1200	1400	1600	1800	2000	
1.6	Load centre distance	c (mm)	600	600	600	600	600	
1.8	Load distance, centre of drive axle to fork	x (mm)	325	325	235	235	305	
1.8.1	Load distance, centre of drive axle to fork, mast reached forward	x1 (mm)	203	203	203	233	233	
1.9	Wheelbase	y (mm)	1480	1480	1480	1480	1550	
Weight	2.1	Service weight (including battery)	Kg	3130	3130	3320	3330	3340
Tyres, chassis	3.1	Tyres: solid rubber, superelastic, pneumatic, polyurethane		polyurethane	polyurethane	polyurethane	polyurethane	polyurethane
3.2	Tyre size, front	mm	Ø343*114	Ø343*114	Ø343*114	Ø343*135	Ø343*135	
3.3	Tyre size, rear *2	mm	Ø285*100	Ø285*100	Ø285*100	Ø343*108	Ø343*108	
3.5	Wheels, number front/rear (*=driven wheels)		1x/2	1x/2	1x/2	1x/2	1x/2	
3.7	Tread width, rear	b11(mm)	1136	1136	1136	1144	1144	
Dimensions	4.1	Tilt of mast/fork carriage forward/backward	α/β(°)	2/4	2/4	2/4	2/4	2/4
4.2	Height, mast lowered	h1 (mm)	2100	2100	2100	2100	2100	
4.4	Lift	h3 (mm)	3000	3000	3000	3000	3000	
4.7	Height of overhead guard	h6 (mm)	2200	2200	2200	2200	2200	
4.10	Height of support arms	h4(mm)	305	305	305	361	361	
4.19	Overall length	l1(mm)	2463	2463	2553	2553	2553	
4.20	Length to face of forks	l2 (mm)	1393	1393	1483	1483	1483	
4.21	Overall width	b1/b2(mm)	1270/1270	1270/1270	1270/1270	1286/1270	1286/1270	
4.22	Fork dimensions ISO	s/e/l (mm)	40*122*1070	40*122*1070	40*122*1070	40*122*1070	40*122*1070	
4.25	Distance between fork-arms	bs (mm)	244-882	244-882	244-882	244-882	244-882	
4.28	Reach distance	l4 (mm)	528	528	438	468	538	
4.34.1	Aisle width for pallets 1000 x 1200 crossways	Ast (mm)	2838	2838	2907	2907	2922	
4.34.2	Aisle width for pallets 800 x 1200 lengthways	Ast (mm)	2897	2897	2980	2980	2984	
4.35	Turning radius	Wa (mm)	1735	1735	1735	1735	1804	
4.37	Length across wheel arms	lr (mm)	1883	1883	1883	1913	1983	
Performance data	5.1	Travel speed, laden/unladen	Km/h	10.2/10.2	10.2/10.2	10.2/10.2	10.2/10.2	10.2/10.2
5.2	Lift speed, laden/unladen	m/s	0.400/0.530	0.390/0.530	0.370/0.530	0.340/0.530	0.310/0.530	
5.3	Lowering speed, laden/unladen	m/s	0.420/0.480	0.420/0.480	0.420/0.480	0.420/0.480	0.420/0.480	
5.8	Max. gradeability, laden/unladen	%	12/15	12/15	11/15	10/15	10/15	
Electric-engine	6.1	Drive motor rating S2 60 min	kW	AC 6.5	AC 6.5	AC 6.5	AC 6.5	AC 6.5
6.2	Lift motor rating at S3 15%	kW	AC 12.8	AC 12.8	AC 12.8	AC 12.8	AC 12.8	
	Steering motor	kW	AC 0.67	AC 0.67	AC 0.67	AC 0.67	AC 0.67	
6.4	Battery voltage, nominal capacity K5	V/Ah	48/400	48/400	48/500	48/500	48/500	
6.5	Battery weight	kg	666	666	855	855	855	
Addition data	8.1	Type of drive control		CURTIS Full AC				
10.1	Operating pressure for attachments	bar	140	140	165	185	210	
10.7	Sound level at the driver's ear according to EN / DIN 12 053	dB(A)	<75	<75	<75	<75	<70	

* CE model

* F2: Means the cold storage truck model F2 are suitable for use in cold storage environments down to -30 °C.

1.2t-2.0t Mast specification

Type	Model	Lifting height h3	Mast lowered h1	Mast extended h4		Free lifting height h2		Tilting range		Load center@600mm				
				Without backrest	With backrest	Without backrest	With backrest	Forward	Backward	1.2t	1.4t	1.6t	1.8t	2.0t
		mm	mm	mm	mm	mm	mm	(°)	(°)	kg	kg	kg	kg	kg
Wide view duplex mast	QAZ0B	2700	1950	3355	3665	340	340	2	4	1200	1400	1600	1800	2000
		3000	2100	3655	3965	340	340	2	4	1200	1400	1600	1800	2000
		3300	2250	3955	4265	340	340	2	4	1200	1400	1600	1800	2000
		3500	2350	4155	4465	340	340	2	4	1200	1400	1600	1800	2000
		3600	2400	4255	4565	340	340	2	4	1200	1400	1600	1800	2000
		4000	2650	4655	4965	340	340	2	4	1200	1400	1600	1800	2000
		4300	2790	4955	5265	340	340	2	4	1200	1400	1600	1800	2000
		4500	2900	5155	5465	340	340	2	4	1200	1400	1600	1800	2000
		4800	3095	5495	5765	340	340	2	4	1200	1400	1600	1800	2000
		5000	3195	5695	5965	340	340	2	4	1200	1400	1600	1800	2000
Full free triplex mast	QAZ0V (imported steel)	4300	2085	4987	5265	1376	1120	2	4	1200	1400	1600	1800	2000
		4500	2165	5170	5465	1495	1200	2	4	1200	1400	1600	1800	2000
		4800	2265	5470	5765	1595	1300	2	4	1200	1400	1600	1800	2000
		5000	2315	5670	5965	1596	1350	2	4	1200	1400	1600	1800	2000
		5500	2490	6170	6465	1796	1525	2	4	1200	1350	1550	1750	1950
		6000	2665	6670	6965	1995	1700	2	4	1200	1250	1450	1650	1850
		6500	2835	7170	7465	2136	1870	2	4	1100	1150	1350	1550	1750
		7000	3020	7670	7965	2350	2055	2	4	1000	1050	1250	1450	1650
		7500	3180	8170	8465	2510	2215	2	4	900	950	1150	1350	1550
		8000	3350	8670	8965	2680	2385	2	4	850	900	1100	1300	1500
		8500	3580	9170	9465	2910	2615	2	4	750	800	1000	1200	1400
		9000	3800	9670	9965	3130	2835	2	4	650	700	900	1100	1300
		9500	3970	10170	10465	3300	3005	2	4	550	600	800	1000	1200
		10000	4100	10670	10965	3430	3135	2	4	450	500	700	900	1100
		10500	4250	11170	11465	3580	3285	2	4	400	450	650	850	1050
11000	4450	11670	11965	3780	3485	2	4	300	350	550	750	950		
11500	4700	12170	12465	4030	3735	2	4	150	200	400	600	800		
12000	4900	12670	12965	4230	3935	2	4	50	100	300	500	700		
12500	5150	13170	13465	4480	4185	2	4	\	\	150	350	550		

Standard Specification

- / PU (polyurethane) driving wheel and load wheels
- / High-capacity battery
- / 4 spools control valves
- / Stepless speed regulation for lifting operation
- / Arm cushion, and impact-proof head cushion
- / 3m duplex mast
- / Adjustable steering wheel
- / Front wheel protection hood
- / Safety pedal
- / 180-degree steering mode
- / Sideshifter
- / Fork tilting (2°/4°)
- / Lift top buffering (Triplex mast)
- / Mast move forward/backward buffering
- / Full AC control
- / Automatic speed reduction when the mast lifting high position (Triplex mast)
- / EPS (Electric Power Steering)
- / Automatic speed reduction at the corner

Options

- / 2.7-5.0m duplex mast
- / 4.3-12.5m full-free triplex mast
- / Various fork lengths
- / Imported high-performance battery
- / Optional large capacity battery 420Ah, 560Ah
- / Full automatic high-frequency charger
- / Other attachments
- / Height monitoring system
- / Alarm lamp, rear headlamp or other lamps

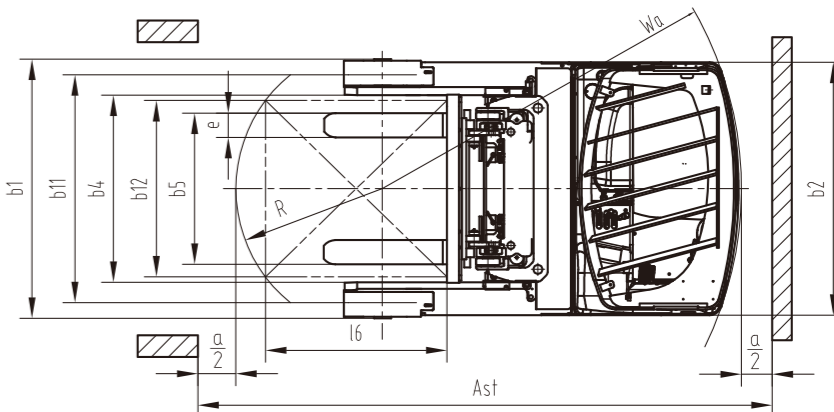
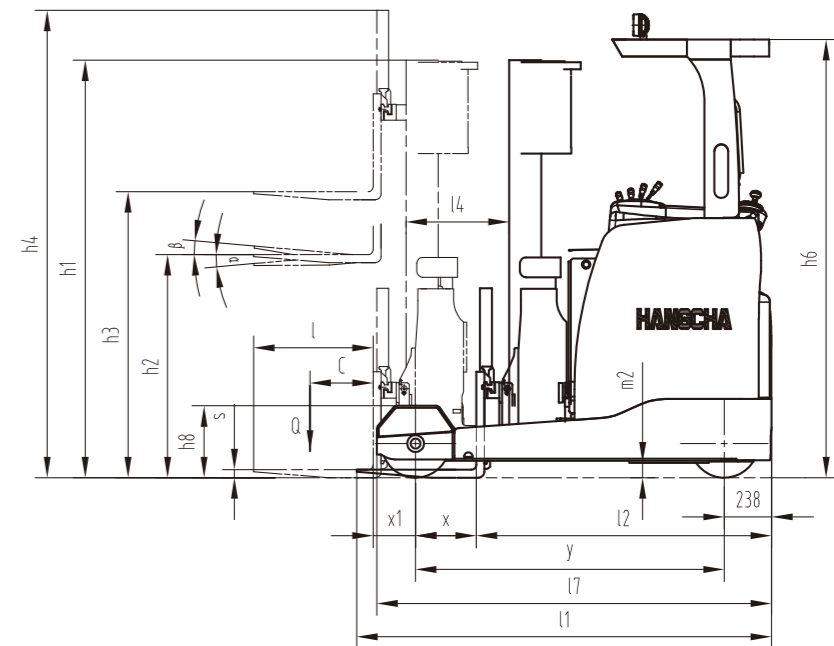

$$Ast=Wa+R+a=Wa+\sqrt{(l_6-x)^2+(\frac{b_{12}}{2})^2}+a$$

